

DRAWING NO.
792296

REVISIONS			
LTR	DESCRIPTION	DATE	APPROVED
A	ECN 42974 LS	10/6/05	

STANDARD MULTI-MIX QUALIFICATION TEST PROCEDURE FOR COMMERCIAL PRODUCTS

<p>"EXCEPT AS MAY BE OTHERWISE PROVIDED BY CONTRACT, THESE DRAWINGS AND SPECIFICATIONS ARE THE PROPERTY OF MERRIMAC INDUSTRIES, INC., AND ARE ISSUED IN STRICT CONFIDENCE AND SHALL NOT BE REPRODUCED, COPIED OR USED AS THE BASIS FOR THE MANUFACTURE OR SALE OF APPARATUS WITHOUT PERMISSION"</p>	APPROVALS	MERRIMAC INDUSTRIES, INC. 41 FAIRFIELD PLACE, WEST CALDWELL, NJ 07006		
	DRAWN BY			
	R McLAUGHLIN 1/06/05			
	CHECKED BY			
	DESIGN ENGINEER			
	R McLAUGHLIN 1/06/05			
	MANUFACTURING ENGINEER			
	L POTOR 01/06/05			
Q/A				
M BHANSALI 1/06/05	SIZE	CAGE CODE	DRAWING NUMBER	REVISION
	A	12457	792296	A
	SCALE	NONE	SHEET 1 OF	22

TABLE OF CONTENTS

1.0	SCOPE	4
2.0	APPLICABLE DOCUMENTS	4
3.0	GENERAL REQUIREMENTS	4
3.1	TEST CONDITIONS	4
3.2	INSPECTION/TESTS	4
3.3	DATA	4
3.4	TEST EQUIPMENT	4
3.5	MECHANICAL	5
3.5.1	DIMENSIONS	5
3.6	ENVIRONMENTAL	5
3.6.1	TEMPERATURE RANGE	5
3.7	PRELIMINARY OPERATIONS	5
4.0	QUALIFICATION TEST PROCEDURES	6
4.1	GROUP I	6
4.1.1	LASER MARK	6
4.1.2	EXTERNAL VISUAL INSPECTION	6
4.1.2.1	MARKING AND SERIALIZATION	6
4.1.2.2	WORKMANSHIP	6
4.1.3	MECHANICAL	6
4.1.3.1	DIMENSIONS	6
4.1.4	ELECTRICAL TEST	6
4.2	GROUP II	6
4.2.1	MOUNT COMPONENTS TO EVALUATION BOARDS	6
4.2.2	EXTERNAL VISUAL INSPECTION	6
4.2.3	MOUNT EVALUATION BOARDS TO ALUMINUM BLOCKS	7
4.2.4	ELECTRICAL TEST	7
4.2.5	EXTERNAL VISUAL INSPECTION	7
4.3	GROUP III	7
4.3.1	EXTERNAL VISUAL INSPECTION	7
4.3.2	RESISTANCE TO SOLDER HEAT	7
4.3.3	EXTERNAL VISUAL INSPECTION	7
4.3.4	MOUNT COMPONENTS TO EVALUATION BOARDS	7
4.3.5	EXTERNAL VISUAL INSPECTION	7
4.3.6	ELECTRICAL TEST	7
4.3.7	EXTERNAL VISUAL INSPECTION	7
4.3.8	MECHANICAL	7
4.4	GROUP IV	8
4.4.1	DIELECTRIC WITHSTANDING VOLTAGE	8
4.4.2	EXTERNAL VISUAL INSPECTION	8
4.4.3	ELECTRICAL TEST	8
4.4.4	THERMAL SHOCK	8
4.4.5	EXTERNAL VISUAL INSPECTION	8
4.4.6	ELECTRICAL TEST	8
4.4.7	MOISTURE RESISTANCE TEST	8
4.4.8	ELECTRICAL TEST	9
4.4.9	EXTERNAL VISUAL INSPECTION	9
4.4.10	STABILIZATION BAKE	9
4.4.11	ELECTRICAL TEST	9
4.5	GROUP V	9
4.5.1	HIGH POWER TEST	9
4.5.2	ELECTRICAL TEST	9
4.6	GROUP VI	9
4.6.1	LIFE TEST	9
4.6.2	EXTERNAL VISUAL INSPECTION	9
4.6.3	MOUNT EVALUATION BOARDS TO ALUMINUM BLOCKS	10
4.6.4	ELECTRICAL TEST	10
4.7	GROUP VI1	10
4.7.1	EXTERNAL VISUAL INSPECTION	10
4.7.2	MECHANICAL	10

-----CONTINUED-----

SIZE	CAGE CODE	DRAWING NUMBER	REVISION
A	12457	792296	A
SCALE	NONE	SHEET 2 OF	22

TABLE OF CONTENTS CONTINUED

4.8	GROUP VIII	
	4.8.1 MICRO-SECTIONING	10
5.0	DETAILED ELECTRICAL TEST PROCEDURE	10
	5.1 ELECTRICAL CHARACTERISTICS	10
	5.2 TEST EQUIPMENT CONFIGURATION	11
	5.2.1 ELECTRICAL TEST SET-UP	11
	5.2.2 HIGH POWER TEST SET-UP	11
	5.2.3 LIFE TEST SET-UP	12
	5.3 CALIBRATION	12
	5.3.1 CALIBRATION ROUTINE	12
	5.4 TEST METHODS	13
	5.4.1 AMPLITUDE RIPPLE	13
	5.4.2 INSERTION LOSS	13
	5.4.3 COUPLING	13
	5.4.4 ISOLATION	13
	5.4.5 VSWR	13
	5.4.6 PHASE	13
	5.4.7 POWER HANDLING	13

TABLES AND FIGURES

TABLE 1:	QUALIFICATION TEST MATRIX	14- 16
TABLE 2:	QUALIFICATION TEST SUMMARY	17 - 21
TABLE 3:	MECHANICAL/DIMENSIONAL INSPECTION DATA SHEET	22
FIGURE 1:	ELECTRICAL TEST SCHEMATIC	11
FIGURE 2:	POWER TEST SCHEMATIC	11
FIGURE 3:	LIFE TEST SCHEMATIC	12

SIZE	CAGE CODE	DRAWING NUMBER	REVISION
A	12457	792296	A
SCALE	NONE	SHEET 3 OF	22

1.0 SCOPE

This procedure defines the methods and sequence of tests used to qualify Multi-Mix commercial products.

2.0 APPLICABLE DOCUMENTS

The following documents form a part of this drawing to the extent specified:

Merrimac: Title Page
Merrimac: Specification Sheet

3.0 GENERAL REQUIREMENTS

3.1 Test Conditions

Unless otherwise specified, electrical performance testing will be conducted under normal ambient conditions as defined below:

Atmospheric Pressure: 28.0 – 31.0 inches of Hg
Temperature: $+25^{\circ}\text{C} \pm 4^{\circ}\text{C}$
Relative humidity: $\leq 90\%$

3.2 Inspection / Tests

Merrimac is responsible for the performance of all tests and inspections.

3.3 Data:

All electrical test data shall be stored electronically in both S-parameter (s4p) format and Tab-delimited Text. Using the file drop down menu select Export/Libra/S4P/dB, angle and store as defined below. Data shall then be stored in Tab-delimited text format by selecting the file drop down menu and selecting the tab-delimited text and storing as defined below. Electronic data shall be stored by serial number within sub folders noting the Group number and test being performed. All performance data shall be traceable to the individual unit via serial number and date code.

3.4 Test Equipment

Depending on availability, equipment used shall be as listed. Equivalent equipment may be substituted. All equipment requiring calibration and used in the performance of these tests shall be maintained in accordance with ISO-10012 and shall bear current calibration decals. All calibration and equipment requirements shall apply to subcontractors; compliance to these requirements shall be demonstrated in their reports to Merrimac.

SIZE A	CAGE CODE 12457	DRAWING NUMBER 792296	REVISION A
SCALE NONE	SHEET 4	OF 22	

<u>DESCRIPTION</u>	<u>MANUFACTURER</u>	<u>MODEL</u>
Network Analyzer	Hewlett-Packard	8753D
S-parameter Test Set	ATN-Microwave	4111A
Electronic calibration	Agilent	N4430A
Temperature Chamber	Tenney Environmental	TC-JR
Humidity Chamber	STD. Environmental Systems	HB/4
Directional Couplers	Merrimac	Applicable CSM-30 Series
Power Meters	Hewlett-Packard	436A
Signal Generator	Hewlett-Packard	E4421B
Temperature Plate	Sigma	TP294
Temp Plate Controller	Sigma	Model C
RF Amplifier	Amplifier Research	200T1G3
Thermocouple	ΩOmega	HH506R

Additional miscellaneous parts, loads, attenuators, isolators and cables shall be 50 Ω type of superior quality to insure accurate, repeatable results.

3.5 Mechanical

3.5.1 Dimensions:

The external physical dimensions of the component shall be inspected per MIL-STD-883F, Method 2016 and shall be in compliance with Merrimac specification.

3.6 Environmental

3.6.1 Temperature Range

Operating:

-55°C to +200°C

Non-Operating

-55°C to +215°C

3.7 Preliminary Operations

Prior to the start of testing, verify all test equipment requiring calibration is operating properly and that valid calibration stickers are in place. Refer to Para 3.4 for calibration and test equipment requirements. Verify all screening and acceptance tests and inspections have been successfully completed, reviewed, and signed by Merrimac QA.

SIZE	CAGE CODE	DRAWING NUMBER	REVISION
A	12457	792296	A
SCALE	NONE	SHEET 5 OF	22

4.0 QUALIFICATION TEST PROCEDURES

See Table 1 for Qualification Test Matrix. The quantity of qualification samples shall be fifty (50).

4.1 Group I

Each qualification unit shall be submitted to tests and inspection as defined in paragraphs 4.1.1 to 4.1.3. For the purpose of qualification all units shall be individually laser marked with non-recurring serial numbers. See Table 1 for order of tests.

4.1.1 Laser Mark

Each unit shall be marked with a non-recurring serial number per Merrimac work instruction procedure CMFG-0003.

4.1.2 External Visual Inspection

Each unit shall be visually inspected per MIL-STD-883F, Method 2009.9

4.1.2.1 Marking and Serialization

Verify all markings are in accordance with Merrimac outline drawing. Verify the unit has been marked with a unique and non-recurring serial number.

4.1.2.2 Workmanship

Visually inspect the unit and verify workmanship to be IAW MIL-HDBK-454, Guideline 9.

4.1.3 Mechanical

4.1.3.1 Dimensions

Each unit shall be inspected per paragraph 3.5 of this document.

4.1.4 Electrical Test

Each unit shall undergo electrical testing at +25°C. The detailed electrical test procedure is described in paragraph 5.0 – 5.4 herein. The Component shall comply with electrical characteristics listed in paragraph 5.1. Data shall also be recorded per paragraph 3.3

4.2 Group II

A sample of twenty-five (25) units from Group I shall be submitted to the following as defined in paragraphs 4.2.1 to 4.2.5. See Table 2 for order of tests.

4.2.1 Mount Components to Evaluation Boards

Each unit shall be mounted on an evaluation board.

4.2.2 External Visual Inspection

Each unit shall be visually inspected per paragraph 4.1.2 of this document.

SIZE A	CAGE CODE 12457	DRAWING NUMBER 792296	REVISION A
SCALE	NONE	SHEET 6 OF	22

4.2.3 Mount Evaluation Boards to Aluminum Blocks

Each evaluation board shall be mounted to aluminum blocks for electrical temperature data.

4.2.4 Electrical Test

Each unit shall undergo electrical testing at -55°C, +25°C, +95°C, +150°C and +200°C. The detailed electrical test procedure is described in paragraph 5.2 – 5.4 herein. The Component shall comply with electrical characteristics listed in paragraph 5.1. Data shall also be recorded per paragraph 3.3

4.2.5 External Visual Inspection

Each unit shall be visually inspected per paragraph 4.1.2 of this document

4.3 Group III

The remaining twenty-five (25) units from group I shall be submitted to the following as defined in paragraphs 4.3.1 – 4.3.6. See Table 2 for order of tests. A controlled sample of five (5) units shall be put aside and not subjected to paragraph 4.3.2.

4.3.1 External Visual Inspection

Each unit shall be visually inspected per paragraph 4.1.2 of this document

4.3.2 Resistance to Solder Heat

Submit group III samples except for the five (5) controlled units to resistance to solder heat per MIL-STD-202F, Method 210F, Condition K in a nitrogen atmosphere.

4.3.3 External Visual Inspection

Each unit shall be visually inspected per paragraph 4.1.2 of this document.

4.3.4 Mount Components to Evaluation Boards

Each unit shall be mounted on an evaluation board.

4.3.5 External Visual Inspection

Each unit shall be visually inspected per paragraph 4.1.2 of this document.

4.3.6 Electrical Test

The detailed electrical test procedure is described in paragraph 5.0 – 5.4 herein. The Component shall comply with electrical characteristics listed in paragraph 5.1. Data shall also be recorded per paragraph 3.3

4.3.7 External Visual Inspection

Each unit shall be visually inspected per paragraph 4.1.2 of this document

4.3.8 Mechanical

Each unit shall be inspected per paragraph 3.5 of this document.

SIZE A	CAGE CODE 12457	DRAWING NUMBER 792296	REVISION A
SCALE NONE	SHEET 7	OF 22	

4.4 Group IV

Group II and Group III are recombined to form Group IV. Group IV units shall be submitted to the following as defined in paragraphs 4.4.1 to 4.4.11. See Table 2 for order of tests. A sample of ten (10) controlled units shall put aside and not subjected to paragraph 4.4.1, 4.4.4, 4.4.7 and 4.4.10. These controlled samples will consist of five (5) random units from Group II and the five (5) control units from Group III.

4.4.1 Dielectric withstanding Voltage

Submit group IV samples except for the ten (10) controlled units to dielectric withstanding voltage per MIL-STD-202F, Method 301 @ +25°C, 1KV-DC for a duration of 60 seconds.

4.4.2 External Visual Inspection

Each unit shall be visually inspected per paragraph 4.1.2 of this document

4.4.3 Electrical Test

Submit Group IV samples to electrical testing at +25°C. The detailed electrical test procedure is described in paragraph 5.0 – 5.4 herein. The Component shall comply with electrical characteristics listed in paragraph 5.1. Data shall also be recorded per paragraph 3.3

4.4.4 Thermal Shock

Submit Group IV samples except for the ten (10) controlled units to thermal shock. Per MIL-STD-883F, Method 1010.8, Condition B for 75 cycles with 15 minute dwell.

4.4.5 External Visual Inspection

Each unit shall be visually inspected per paragraph 4.1.2 of this document

4.4.6 Electrical Test

Submit Group IV samples to electrical testing at +25°C. The detailed electrical test procedure is described in paragraph 5.0 – 5.4 herein. The Component shall comply with electrical characteristics listed in paragraph 5.1. Data shall also be recorded per paragraph 3.3

4.4.7 Moisture Resistance Test

Submit Group IV samples except for the ten (10) controlled units to moisture resistance test. Perform moisture resistance from -25°C to +65°C for a duration of 2 hours @ 90% humidity. Then increase the humidity to 95% for a dwell of 4 hours. Then ramp the temperature to +25°C within 2 hours and repeat procedure for 10 cycles. Then dwell for 3 hours @ -10°C. Use MIL-STD-202G, Method 106G requirements as applicable.

SIZE A	CAGE CODE 12457	DRAWING NUMBER 792296	REVISION A
SCALE NONE	SHEET 8	OF 22	

4.4.8 Electrical Test

Submit Group IV samples to electrical testing at +25°C. The detailed electrical test procedure is described in paragraph 5.0 – 5.4 herein. The Component shall comply with electrical characteristics listed in paragraph 5.1. Data shall also be recorded per paragraph 3.3

4.4.9 External Visual Inspection

Each unit shall be visually inspected per paragraph 4.1.2 of this document

4.4.10 Stabilization Bake

Submit Group IV samples except for the ten (10) controlled units to Stabilization Bake @ +100°C for 1 hour.

4.4.11 Electrical Test

Submit Group V samples to electrical testing at +25°C. The detailed electrical test procedure is described in paragraph 5.0 – 5.4 herein. The Component shall comply with electrical characteristics listed in paragraph 5.1. Data shall also be recorded per paragraph 3.3

4.5 Group V

Two (2) units from Group IV shall be submitted to the following as defined in paragraphs 4.5.1 to 4.5.3. See Table 2 for order of tests.

4.5.1 High Power Test

Each unit will be subjected to high power testing as defined in paragraph 5.4.7 and shown in figure 3. The unit shall dwell for a minimum of one (1) hour @ the components rated input power.

4.5.2 Electrical Test

Submit Group V samples to electrical testing at +25°C. The detailed electrical test procedure is described in paragraph 5.0 – 5.4 herein. The Component shall comply with electrical characteristics listed in paragraph 5.1. Data shall also be recorded per paragraph 3.3

4.6 Group VI

Six (6) units will be picked from Group IV and shall be submitted to the following as defined in paragraphs 4.6.1 to 4.6.4. See Table 2 for order of tests.

4.6.1 Life Testing

Submit Group VI samples to life testing. Three (3) units shall be connected in series with a 150 watts Fc signal applied @ the input of the DUT for a duration of 96 hours. A base plate temperature of 100°C shall be achieved with the use a temperature plate. See figure 3 for life testing schematic.

4.6.2 External Visual Inspection

Each unit shall be visually inspected per paragraph 4.1.2 of this document

SIZE A	CAGE CODE 12457	DRAWING NUMBER 792296	REVISION A
SCALE NONE	SHEET 9	OF 22	

4.6.3 Mount Evaluation Boards to Aluminum Blocks

Each evaluation board shall be mounted to aluminum blocks for electrical temperature data.

4.6.4 Electrical Test

Each unit shall undergo electrical testing at -55°C, +25°C, +95°C, +150°C and +200°C. The detailed electrical test procedure is described in paragraph 5.0 – 5.4 herein. The Component shall comply with electrical characteristics listed in paragraph 5.1. Data shall also be recorded per paragraph 3.3

4.7 Group VII

Twenty-five (25) units from Group IV that did not go through Group V or Group VI testing shall be submitted to the following as defined in paragraphs 4.7.1 to 4.7.2. See Table 2 for order of tests.

4.7.1 External Visual Inspection

Each unit shall be visually inspected per paragraph 4.1.2 of this document

4.7.2 Mechanical

Each unit shall be inspected per paragraph 3.5 of this document.

4.8 Group VIII

Group VIII shall consist of eight (8) units. One (1) control unit from Group III. One (1) control unit from Group IV that did not go through Group III. One (1) unit from Group V, Two (2) units from Group VI and three (3) units from Group VII. These units shall be submitted to the following as defined in paragraph 4.8.1

4.8.1 Micro-Sectioning

Submit all units from group VIII to micro-sectioning per Merrimac work instruction procedure CMFG-0043.

5.0 **DETAILED ELECTRICAL TEST PROCEDURE**

Electrical specifications are per Merrimac specification sheet. The base-plate temperature of the DUT shall be +25°C unless otherwise specified.

5.1 Electrical Characteristics

The Component shall have the meet electrical characteristics defined on the components specification sheet when measured in a 50-ohm system and tested per paragraphs 5.2 – 5.4:

SIZE A	CAGE CODE 12457	DRAWING NUMBER 792296	REVISION A
SCALE NONE	SHEET 10	OF 22	

5.2 Test Equipment Configuration

- 5.2.1 The electrical test set-up for paragraph 5.4.1 through 5.4.6 shall be configured as depicted in Figure 1.

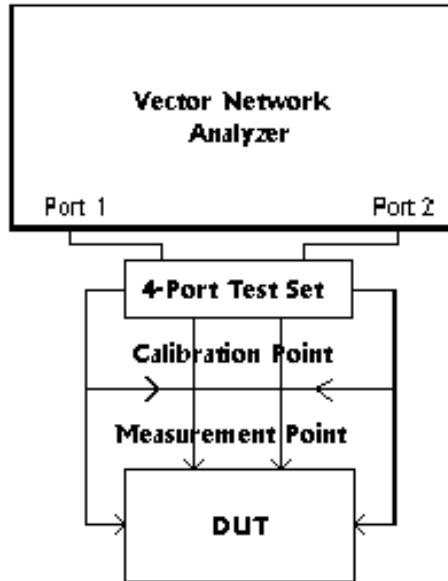

Figure 1 Electrical Test Schematic

- 5.2.2 The Power test set-up for paragraph 5.4.7 shall be configured as depicted in Figure 2.

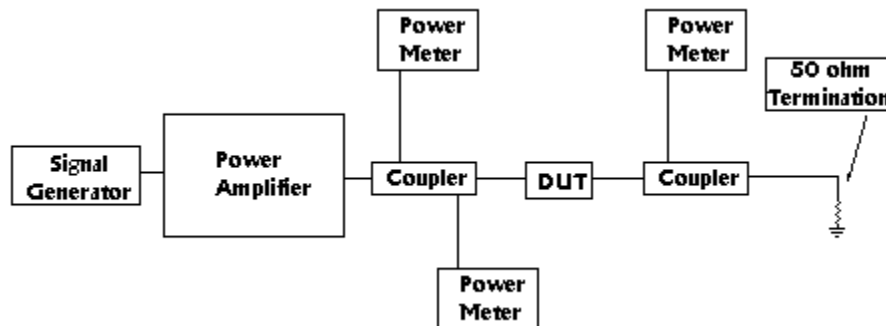

Figure 2 Power Test Schematic

SIZE A	CAGE CODE 12457	DRAWING NUMBER 792296	REVISION A
SCALE NONE	SHEET 11	OF 22	

5.2.3 The Life test set-up for paragraph 4.6.1 shall be configured as depicted in Figure 3.

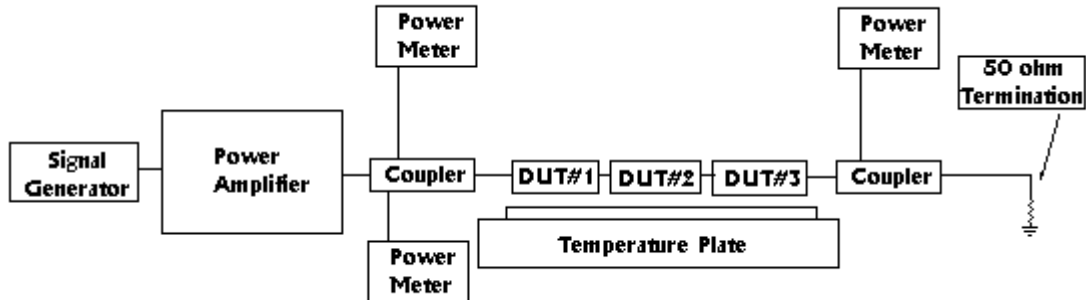

Figure 3 Life Test Schematic

5.3 Calibration

5.3.1 Calibration Routine

The Multi-port Network Analyzer test set-up (Figure 2) shall be calibrated per the standard SOLT (Short, Open, Load, Through) calibration procedure. Insure that the correct calibration standards are used for the calibration

- ◆ From the Calibrate drop down menu select standard calibration.
- ◆ Set up the Measurement Parameters window as follows:
 - Start Frequency: Start of components operating Range MHz
 - Stop Frequency: End of components operating Range MHz
 - Step Size: = (Stop Freq.-Start Freq./200)
 - Source Power Use software's default settings
 - Averaging Use software's default settings
 - IF Bandwidth 300 Hz
 - Sweep Mode: Stepped
- ◆ When done entering in the information click OK
- ◆ The two (2) following windows that appear are for de-embedding these functions are not used so we accept the default settings and click OK
- ◆ Following the instructions displayed, perform a calibration using the short, open, through, and 50-ohm terminations included in the calibration kit.
- ◆ Store the calibration

SIZE	CAGE CODE	DRAWING NUMBER	REVISION
A	12457	792296	A
SCALE	NONE	SHEET 12 OF	22

5.4 Test Methods

From the display drop down menu select display configuration. Recall a predefined configuration for the type of device being tested. Connect the DUT and click the measure button and wait until the test is complete. The components performance shall be verified in accordance with paragraphs 5.4.1 – 5.4.6. Electrical data shall be stored using Multi-Port software per paragraph 3.3.

5.4.1 Amplitude Balance

Using the marker function on the software find the worst-case point displayed on the Amplitude Balance plot within the appropriate frequency range and verify compliance.

5.4.2 Insertion Loss

Using the marker function on the software find the worst-case point displayed on the insertion loss plot within the appropriate frequency range and verify compliance.

5.4.3 Coupling

Using the marker function on the software, and using the same frequency point from which the worst-case insertion loss data was taken. Look at both coupling plot S41 & S31 and enter readings within the appropriate frequency range and verify compliance.

5.4.4 Isolation

Using the marker function on the software find the worst-case point displayed on the Isolation plot within the appropriate frequency range and verify compliance.

5.4.5 VSWR

Using the marker function on the software find the worst-case point displayed on each of the corresponding Return Loss plots within the appropriate frequency range. (S11, S22, S33, S44) and verify compliance.

5.4.6 Phase Balance

Using the marker function on the software find the worst-case point displayed on the Phase Balance plot within the appropriate frequency range and verify compliance.

5.4.7 Power Handling*

Assemble test set as shown in Figure 2. Adjust signal generator output to achieve the desired Fc signal at the input port of the DUT. The duration of the test shall be for a minimum of one (1) hour.

* Due to equipment power limitations, components such as attenuators, isolators and additional miscellaneous parts may be added to figure 2. However, in this event they shall be 50 Ω type of superior quality to insure accurate, repeatable results.

SIZE A	CAGE CODE 12457	DRAWING NUMBER 792296	REVISION A
SCALE NONE	SHEET 13	OF 22	

TABLE 1: QUALIFICATION TEST MATRIX
SAMPLE SIZE IS FIFTY (50) UNITS

GROUP I

PERFORM ON ALL UNITS

REQUIREMENT DESCRIPTION	MERRIMAC METHOD PARAGRAPH
LASER MARK	4.1.1
EXTERNAL VISUAL INSPECTION	4.1.2
MECHANICAL	3.5
ELECTRICAL TEST (+25°C)	4.1.4

GROUP II

PERFORM ON TWENTY FIVE (25) UNITS WHICH HAVE BEEN SUBJECTED TO GROUP I TESTING

REQUIREMENT DESCRIPTION	MERRIMAC METHOD PARAGRAPH
MOUNT COMPONENTS TO EVALUATION BOARDS	4.2.1
EXTERNAL VISUAL INSPECTION	4.1.2
MOUNT EVALUATION BOARDS TO ALUMINUM	4.2.3
ELECTRICAL TEST (-55°C)	4.2.4
ELECTRICAL TEST (+25°C)	4.2.4
ELECTRICAL TEST (+95°C))	4.2.4
ELECTRICAL TEST (+150°C)	4.2.4
ELECTRICAL TEST (+200°C)	4.2.4
EXTERNAL VISUAL INSPECTION	4.1.2

GROUP III

PERFORM ON THE REMAINING TWENTY FIVE (25) UNITS WHICH HAVE BEEN SUBJECTED TO GROUP I TESTING, BUT NOT SUBJECTED TO GROUP II TESTING.
*A CONTROLLED SAMPLE OF FIVE (5) UNITS SHALL BE PUT ASIDE AND NOT SUBJECTED TO PARAGRAPH 4.3.2 FOR REASONS OF COMPARISON.

REQUIREMENT DESCRIPTION	MERRIMAC METHOD PARAGRAPH
EXTERNAL VISUAL INSPECTION	4.1.2
RESITANCE TO SOLDERING HEAT *	4.3.2
EXTERNAL VISUAL INSPECTION	4.1.2
MOUNT COMPONENTS TO EVALUATION BOARDS	4.3.4
EXTERNAL VISUAL INSPECTION	4.1.2
ELECTRICAL TEST (+25°C)	4.3.6
EXTERNAL VISUAL INSPECTION	4.1.2
MECHANICAL	3.5

-----CONTINUED-----

SIZE A	CAGE CODE 12457	DRAWING NUMBER 792296	REVISION A
SCALE NONE	SHEET 14	OF 22	

**TABLE 1: QUALIFICATION TEST MATRIX
CONTINUED**

GROUP IV GROUP II AND GROUP III ARE TO BE RECOMBINED TO FORM GROUP IV. A SAMPLE OF TEN (10) CONTROL UNITS SHALL BE PUT ASIDE. THE CONTROL UNITS SHALL NOT BE SUBJECTED TO PARAGRAPHS 4.4.1, 4.4.4, 4.4.7 AND 4.4.10. THE CONTROLLED SAMPLES WILL CONSIST OF FIVE (5) RANDOM UNITS FROM GROUP II AND THE FIVE (5) CONTROL UNITS FROM GROUP III.

REQUIREMENT DESCRIPTION	MERRIMAC METHOD PARAGRAPH
DIELECTRIC WITHSTANDING VOLTAGE	4.4.1
EXTERNAL VISUAL INSPECTION	4.1.2
ELECTRICAL TEST (+25°C)	4.4.3
THERMAL SHOCK	4.4.4
EXTERNAL VISUAL INSPECTION	4.1.2
ELECTRICAL TEST (+25°C)	4.4.6
MOISTURE RESISTANCE TEST	4.4.7
ELECTRICAL TEST (+25°C)	4.4.8
EXTERNAL VISUAL INSPECTION	4.1.2
STABILIZATION BAKE	4.4.10
ELECTRICAL TEST (+25°C)	4.4.11

GROUP V PERFORM ON TWO (2) UNITS FROM GROUP IV

REQUIREMENT DESCRIPTION	MERRIMAC METHOD PARAGRAPH
HIGH POWER TEST	5.4.7
ELECTRICAL TEST (+25°C)	4.5.2

GROUP VI PERFORM ON SIX (6) UNITS FROM GROUP IV.

REQUIREMENT DESCRIPTION	MERRIMAC METHOD PARAGRAPH
LIFE TEST	4.6.1
EXTERNAL VISUAL INSPECTION	4.1.2
MOUNT EVALUATION BOARDS TO ALUMINUM	4.6.3
ELECTRICAL TEST (-55°C)	4.6.4
ELECTRICAL TEST (+25°C)	4.6.4
ELECTRICAL TEST (+95°C))	4.6.4
ELECTRICAL TEST (+150°C)	4.6.4
ELECTRICAL TEST (+200°C)	4.6.4

-----CONTINUED-----

SIZE A	CAGE CODE 12457	DRAWING NUMBER 792296	REVISION A
SCALE NONE	SHEET 15	OF 22	

**TABLE 1: QUALIFICATION TEST MATRIX
CONTINUED**

GROUP VII PERFORM ON TWENTY FIVE (25) UNITS FROM GROUP IV.

REQUIREMENT DESCRIPTION	MERRIMAC METHOD PARAGRAPH
EXTERNAL VISUAL INSPECTION	4.1.2
MECHANICAL	3.5

GROUP VIII PERFORM ON A SAMPLE OF EIGHT (8) UNITS CONSISTING OF ONE (1) CONTROL UNIT FROM GROUP III, ONE (1) CONTROL UNIT FROM GROUP IV THAT DID NOT GO THROUGH GROUP III TESTING, ONE (1) UNIT FROM GROUP V, TWO (2) UNITS FROM GROUP VI AND THREE (3) UNITS FROM GROUP VII.

REQUIREMENT DESCRIPTION	MERRIMAC METHOD PARAGRAPH
MICRO-SECTIONING	4.8.1

SIZE A	CAGE CODE 12457	DRAWING NUMBER 792296	REVISION A
SCALE NONE	SHEET 16	OF 22	

DRAWING NO.

792296

**TABLE 2
QUALIFICATION TEST SUMMARY**

MERRIMAC MODEL: _____

DATE CODE: _____

SUBGROUP I (50 SAMPLES)

TEST	PARA	QTY ACC	QTY REJ	S/N REJ	DATE	TECHNICIAN STAMP	QC STAMP
EXTERNAL VISUAL INSPECTION	4.1.2						
MECHANICAL	3.5						
ELECTRICAL TEST (+25°C)	4.1.4						

S/N's _____

SUBGROUP II (25 SAMPLES FROM SUBGROUP I)

TEST	PARA	QTY ACC	QTY REJ	S/N REJ	DATE	TECHNICIAN STAMP	QC STAMP
MOUNTING COMPONENTS TO TEST BOARDS	4.2.1						
EXTERNAL VISUAL INSPECTION	4.1.2						
MOUNT EVALUATION BOARDS TO ALUMINUM BLOCKS	4.2.3						
ELECTRICAL TEST (-55°C)	4.2.4						
ELECTRICAL TEST (+25°C)	4.2.4						
ELECTRICAL TEST (+95°C)	4.2.4						
ELECTRICAL TEST (+150°C)	4.2.4						
ELECTRICAL TEST (+200°C)	4.2.4						
EXTERNAL VISUAL INSPECTION	4.1.2						

S/N's _____

-----CONTINUED-----

SIZE A	CAGE CODE 12457	DRAWING NUMBER 792296	REVISION A
SCALE NONE	SHEET 17	OF 22	

**TABLE 2: QUALIFICATION TEST SUMMARY
CONTINUED**

MERRIMAC MODEL: _____

DATE CODE: _____

SUBGROUP III (REMAINING 25 SAMPLES FROM SUBGROUP I)

TEST	PARA	QTY ACC	QTY REJ	S/N REJ	DATE	TECHNICIAN STAMP	QC STAMP
EXTERNAL VISUAL INSPECTION	4.1.2						
*RESISTANCE TO SOLDERING HEAT	4.3.2						
EXTERNAL VISUAL INSPECTION	4.1.2						
MOUNT COMPONENTS TO EVALUATION BOARDS	4.3.4						
EXTERNAL VISUAL INSPECTION	4.1.2						
ELECTRICAL TEST (+25°C)	4.3.6						
EXTERNAL VISUAL INSPECTION	4.1.2						
MECHANICAL	3.5						

S/N's _____

CONTROL UNITS S/N's _____

* CONTROL UNITS SHALL BE PUT ASIDE AND NOT SUBJECTED TO PARAGRAPHS 4.3.2

-----CONTINUED-----

SIZE A	CAGE CODE 12457	DRAWING NUMBER 792296	REVISION A
SCALE NONE	SHEET 18	OF 22	

**TABLE 2: QUALIFICATION TEST SUMMARY
CONTINUED**

MERRIMAC MODEL: _____

DATE CODE: _____

SUBGROUP IV (50 SAMPLES RECOMBINED SUBGROUP II AND SUBGROUP III)

TEST	PARA	QTY ACC	QTY REJ	S/N REJ	DATE	TECHNICIAN STAMP	QC STAMP
** DIELECTRIC WITHSTANDING VOLTAGE	4.4.1						
EXTERNAL VISUAL INSPECTION	4.1.2						
ELECTRICAL TEST (+25°C)	4.4.3						
* THERMAL SHOCK	4.4.4						
EXTERNAL VISUAL INSPECTION	4.1.2						
ELECTRICAL TEST (+25°C)	4.4.6						
* MOISTURE RESISTANCE TEST	4.4.7						
ELECTRICAL TEST (+25°C)	4.4.8						
EXTERNAL VISUAL INSPECTION	4.1.2						
* STABILIZATION BAKE	4.4.10						
ELECTRICAL TEST (+25°C)	4.4.11						

S/N's _____

CONTROL UNITS S/N's _____

** CONTROL UNITS SHALL BE PUT ASIDE AND NOT SUBJECTED TO PARAGRAPH 4.4.1, 4.4.4, 4.4.7 & 4.4.10.

-----CONTINUED-----

SIZE A	CAGE CODE 12457	DRAWING NUMBER 792296	REVISION A
SCALE NONE	SHEET 19	OF 22	

**TABLE 2: QUALIFICATION TEST SUMMARY
CONTINUED**

MERRIMAC MODEL: _____

DATE CODE: _____

SUBGROUP V (2 SAMPLES FROM SUBGROUP IV)

TEST	PARA	QTY ACC	QTY REJ	S/N REJ	DATE	TECHNICIAN STAMP	QC STAMP
HIGH POWER TEST	4.5.1						
ELECTRICAL TEST (+25°C)	4.5.2						

S/N's _____

SUBGROUP VI (6 SAMPLES FROM SUBGROUP IV)

TEST	PARA	QTY ACC	QTY REJ	S/N REJ	DATE	TECHNICIAN STAMP	QC STAMP
LIFE TEST	4.6.1						
EXTERNAL VISUAL INSPECTION	4.1.2						
MOUNT EVALUATION BOARDS TO ALUMINUM BLOCKS	4.6.2						
ELECTRICAL TEST (-55°C)	4.6.3						
ELECTRICAL TEST (+25°C)	4.6.3						
ELECTRICAL TEST (+95°C)	4.6.3						
ELECTRICAL TEST (+150°C)	4.6.3						
ELECTRICAL TEST (+200°C)	4.6.3						

S/N's _____

-----CONTINUED-----

SIZE A	CAGE CODE 12457	DRAWING NUMBER 792296	REVISION A
SCALE NONE	SHEET 20	OF 22	

**TABLE 2: QUALIFICATION TEST SUMMARY
CONTINUED**

SUBGROUP VII (25 SAMPLES FROM SUBGROUP IV)

TEST	PARA	QTY ACC	QTY REJ	S/N REJ	DATE	TECHNICIAN STAMP	QC STAMP
EXTERNAL VISUAL INSPECTION	4.1.2						
MECHANICAL	3.5						

S/N's _____

SUBGROUP VIII (8 SAMPLES THAT CONSIST OF ONE (1) CONTROL UNIT FROM GROUP III. ONE (1) CONTROL UNIT FROM GROUP IV THAT DID NOT GO THROUGH GROUP III TESTING. ONE (1) UNIT FROM GROUP V, TWO (2) UNITS FROM GROUP VI AND THREE (3) UNITS FROM GROUP VII.)

TEST	PARA	QTY ACC	QTY REJ	S/N REJ	DATE	TECHNICIAN STAMP	QC STAMP
MICRO-SECTIONING	4.8.1						

S/N's _____

SIZE A	CAGE CODE 12457	DRAWING NUMBER 792296	REVISION A
SCALE NONE	SHEET 21	OF 22	

**TABLE 3
MECHANICAL/DIMENSIONAL INSPECTION DATA**

MERRIMAC MODEL: _____

S/N: _____

DESCRIPTION	DIMENSION (INCHES)	TOLERANCE (INCHES)	ACTUAL	COMPLIANT? (Y/N)
LENGTH	See Specification Sheet	$\pm.005$		
HEIGHT	See Specification Sheet	$\pm.005$		
WIDTH	See Specification Sheet	$\pm.005$		
FOOTPRINTS	See Specification Sheet	$\pm.008$		
FOOTPRINT ISOLATIONS	See Specification Sheet	$\pm.003$		

INSPECTED BY: _____

DATE: _____

SIZE A	CAGE CODE 12457	DRAWING NUMBER 792296	REVISION A
SCALE NONE	SHEET 22	OF 22	22