

# FME270-461 EMI Input Filters

## 0 TO 400 VOLT INPUT – 1.5 AMP

### FEATURES

- Attenuation to 50 dB at 500 kHz
- Operating temperature -55° to +125°C
- Nominal 270 volt input, 0 to 400 volt operation
- Transient rating to 500 volt for 100 ms
- Up to 1.5 amps throughput current
- Compliant to
- MIL-STD-461C, CE03



### DESCRIPTION

Interpoint® FME270 Series™ EMI filters are specifically designed to reduce the reflected input ripple current of Interpoint's high frequency DC-DC converters. FME270 filters minimize electromagnetic interference (EMI) for the MHP270 Series of converters. The FME270 filters are manufactured in our fully certified and qualified MIL-PRF-38534 Class H production facility and packaged in hermetically sealed steel cases. They are ideal for use in programs requiring high reliability and small size. These filters are intended for use in 270 volt applications which must meet MIL-STD-461C CE03 levels of conducted emissions. One filter can be used with multiple converters up to the rated output current of the filter.

### INPUT RIPPLE AND EMI

Switching DC-DC converters naturally generate two noise components on the power input line: differential noise and common mode noise. Input ripple current refers to both of these components. Differential noise occurs between the positive input and input common. Most Interpoint converters have an input filter that reduces differential noise which is sufficient for many applications. Common mode noise occurs across stray capacitances between the converter's power train components and the baseplate (bottom of the package) of the converter.

Where low noise currents are required to meet MIL-STD-461C, a power line filter is needed. The FME270 EMI power line filters reduces the common mode and differential noise generated by the converters. FME270 filters reduce input ripple current by as much as 50 dB at 500 kHz and 55 dB at 1 MHz when used in conjunction with Interpoint's DC-DC converters.

Place the filter as close as possible to the converter for optimum performance. The baseplates of the filter and the converter should be connected with the shortest and widest possible conductors.

### TRANSIENTS

A transient of -500 to +500 volt for up to 100 ms will not damage the filter but will be passed on to the converter:

### OPERATION OVER TEMPERATURE

The FME270-461 Series filters are rated for full power operation from -55°C to +125°C case temperature. Current is derated linearly to zero at +135°C case temperature.

### INSERTION LOSS

The maximum dc insertion loss at full load and nominal input voltage represents a power loss of less than 4%.

### PACKAGING

FME270-461 filters are sealed in metal hermetic side-leaded packages. See cases U, V, W, Y, and Z.

# FME270-461 EMI Input Filters

0 TO 400 VOLT INPUT - 1.5 AMP

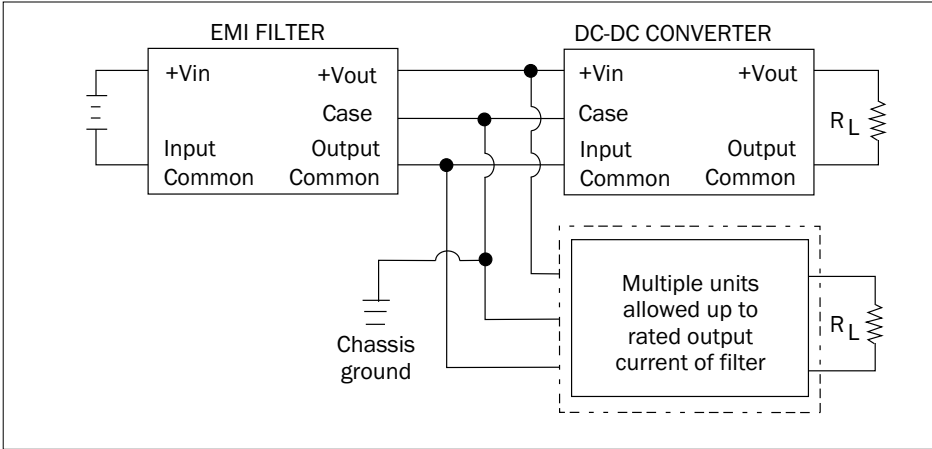

FIGURE 1: CONNECTION DIAGRAM

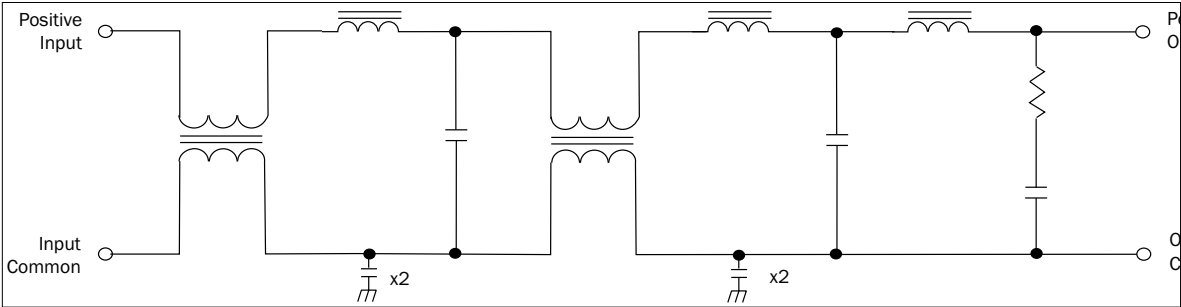

FIGURE 2: FME270-461 BLOCK DIAGRAM

# FME270-461 EMI Input Filters

## 0 TO 400 VOLT INPUT – 1.5 AMP

### PIN OUT

Pin <sup>1</sup>	Designation
1, 2, 3	Positive Input
4, 5, 6	Input Common
7, 8, 9	Output Common
10, 11, 12	Positive Output
—	Case Ground <sup>2</sup>

- Notes
1. All pins must be connected.
  2. The baseplate is the only case ground connection and should directly contact chassis ground.

TABLE 1: PIN OUT

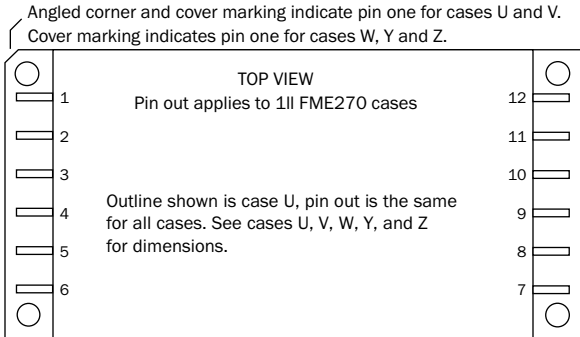

FIGURE 3: PIN OUT

# FME270-461 EMI Input Filters

## 0 TO 400 VOLT INPUT – 1.5 AMP

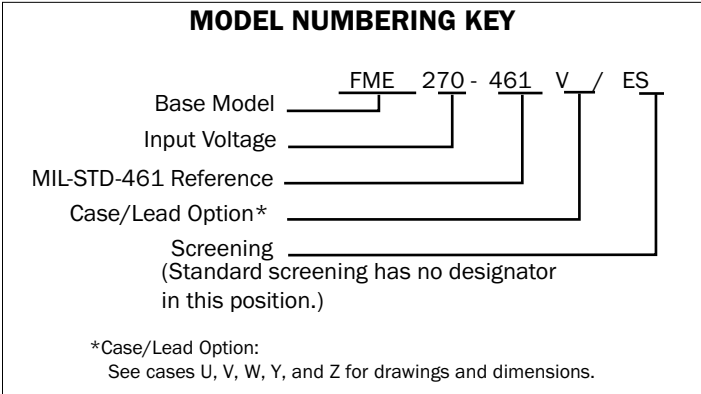

FIGURE 4:MODEL NUMBER KEY

<b>MODEL NUMBER OPTIONS <sup>1</sup></b>			
<b>TO DETERMINE THE MODEL NUMBER ENTER ONE OPTION FROM EACH CATEGORY IN THE FORM BELOW.</b>			
CATEGORY	Base Model and Input Voltage	Case Option <sup>2</sup>	Screening <sup>3</sup>
<b>OPTIONS</b>	FME270-461	(flanged, short leads, standard "U" case, leave blank) V (flanged, leads bent down) W (tabbed, leads bent up) Y (tabbed, short leads) Z (tabbed, leads bent down)	(Standard, leave blank)  ES
<b>FILL IN FOR MODEL # <sup>4</sup></b>	<u>FME270-461</u>	_____ /	_____
Notes: 1. See Model Numbering Key above for an example of a model number. 2. Case Options: Case U is the standard case, leave the case option blank for case U. For case V, W, Y or Z, place the appropriate letter in the case option position. 3. Screening: See Table 5 on page 11 for more information. Standard screening does not require a designator, leave the Screening Option position blank. "ES" does require "ES" on the Screening Option position. 4. If ordering by model number add a "-Q" to request solder dipped leads (FME270-461/ES-Q).			

TABLE 2: :MODEL NUMBER OPTIONS

# FME270-461 EMI Input Filters

## 0 TO 400 VOLT INPUT – 1.5 AMP

TABLE 3: OPERATING CONDITIONS, 28 V<sub>IN</sub>, 100% LOAD, UNLESS OTHERWISE SPECIFIED.

MODEL		FME270-461			UNITS
PARAMETER	CONDITIONS	MIN	TYP	MAX	
LEAD SOLDERING TEMPERATURE <sup>1</sup>	10 seconds max.	–	–	300	°C
STORAGE TEMPERATURE <sup>1</sup>		-65	–	+150	°C
CASE OPERATING TEMPERATURE <sup>1</sup>	FULL POWER	-55	–	+125	°C
	ABSOLUTE <sup>1</sup>	-55	–	+135	
DERATING OUTPUT POWER/CURRENT <sup>1</sup>	LINEARLY	From 100% A at 95 °C to 10 A at 125 °C			
ISOLATION, ANY PIN TO CASE	500 VDC AT 25 °C	100	–	–	Megohms

Notes

1. Guaranteed by characterization test and/or analysis. Not a production test.

TABLE 4: ELECTRICAL CHARACTERISTICS: -55 TO +125 °C CASE, 270 V<sub>IN</sub>, UNLESS OTHERWISE SPECIFIED.

MODEL		FME270-461			UNITS
PARAMETER	CONDITIONS	MIN	TYP	MAX	
INPUT VOLTAGE <sup>1</sup>	CONTINUOUS	0	270	400	V
	TRANSIENT 100 ms <sup>2</sup>	-500	–	500	
NOISE REJECTION	500 KHZ	40	50	–	dB
	1 MHZ	45	55	–	
DC RESISTANCE (R <sub>DC</sub> )	T <sub>C</sub> = 25 °C	–	–	2.0	Ω
	T <sub>C</sub> = 125 °C	–	–	3.2	
CAPACITANCE 25 °C	ANY PIN TO CASE	–	60,000	–	pF
OUTPUT VOLTAGE <sup>1</sup>	STEADY STATE	$V_{OUT} = V_{IN} - I_{IN} (R_{DC})$			V
OUTPUT CURRENT <sup>1</sup>	STEADY STATE	–	–	1.5	A
POWER DISSIPATION <sup>1</sup> AT MAXIMUM CURRENT	T <sub>C</sub> = 25 °C	–	–	4.5	W
	T <sub>C</sub> = 125 °C	–	–	7.2	

Notes

1. Guaranteed by characterization test and/or analysis. Not a production test.

2. Transients up to ±500 volts will not damage the filter but will be passed through the filter.

# FME270-461 EMI Input Filters

## 0 TO 400 VOLT INPUT – 1.5 AMP

TOP VIEW CASE U  
Flanged case, short leads

Case "U" does not require an option in the Case Option position of the model number.

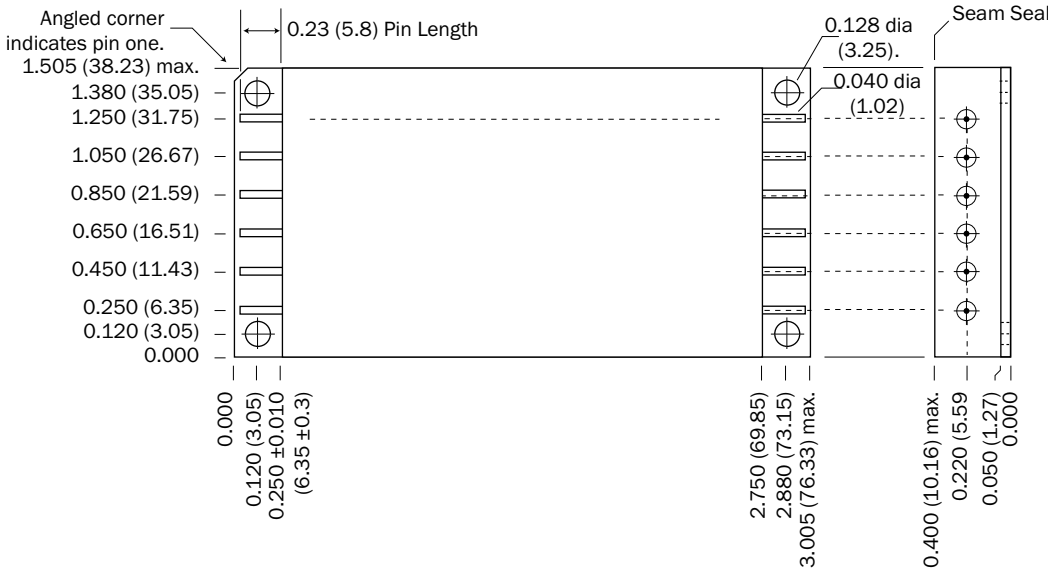

Weight: 86 grams maximum

Case dimensions in inches (mm)  
Tolerance ±0.005 (0.13) for three decimal places  
±0.01 (0.3) for two decimal places  
unless otherwise specified

**CAUTION**  
Heat from reflow or wave soldering may damage the device. Solder pins individually with heat application not exceeding 300 °C for 10 seconds per pin.

**Materials**  
Header Cold Rolled Steel/Nickel/Gold  
Cover Kovar/Nickel  
Pins #52 alloy/Gold, compression glass seal  
Gold plating of 50 - 150 microinches is included in pin diameter  
Seal Hole: 0.120 ±0.002 (3.05 ±0.05)

Please refer to the numerical dimensions for accuracy.

FIGURE 5: CASE U - FME270-461

# FME270-461 EMI Input Filters

## 0 TO 400 VOLT INPUT – 1.5 AMP

Flanged case, down leaded

Case "V" requires a "V" in the Case Option position of the model number.

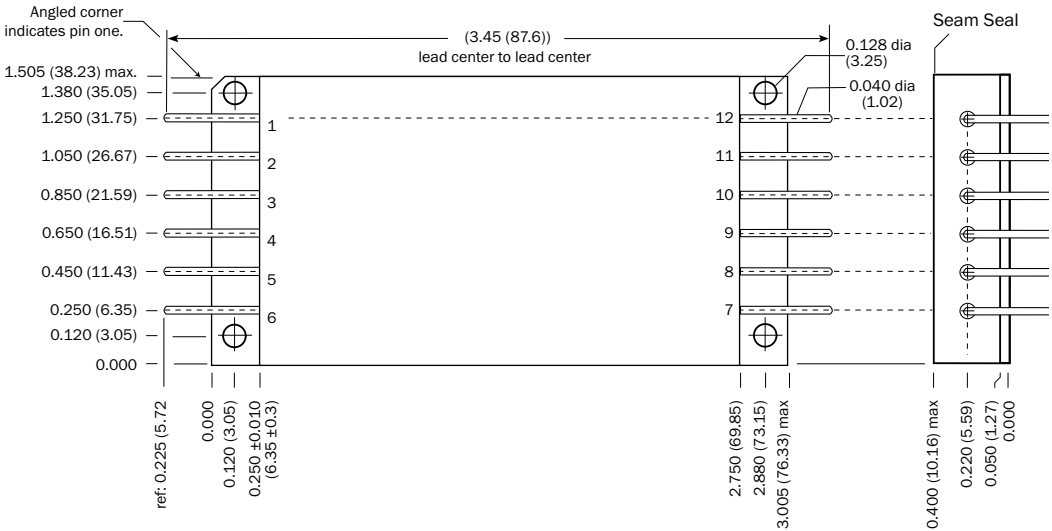

Weight: 86 grams maximum

Case dimensions in inches (mm)  
 Tolerance  $\pm 0.005$  (0.13) for three decimal places  
 $\pm 0.01$  (0.3) for two decimal places  
 unless otherwise specified

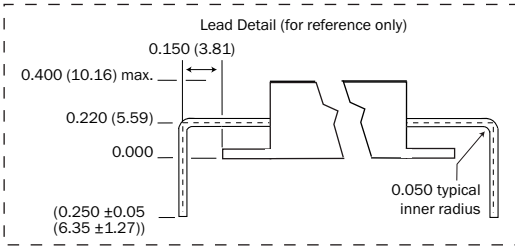

**CAUTION**  
 Heat from reflow or wave soldering may damage the device. Solder pins individually with heat application not exceeding 300 °C for 10 seconds per pin.

**Materials**  
 Header Cold Rolled Steel/Nickel/Gold  
 Cover Kovar/Nickel  
 Pins OFHC copper/gold, compression glass seal  
 Gold plating of 50 - 150 microinches  
 Included in pin diameter  
 Seal Hole: 0.120  $\pm$  0.002 (3.05  $\pm$  0.05)

Please refer to the numerical dimensions for accuracy

FIGURE 6: CASE V - FME270-461V

# FME270-461 EMI Input Filters

## 0 TO 400 VOLT INPUT - 1.5 AMP

TOP VIEW CASE W  
Tabbed case, up-leaded

Case "W" requires a "W" in the Case Option position of the model number.

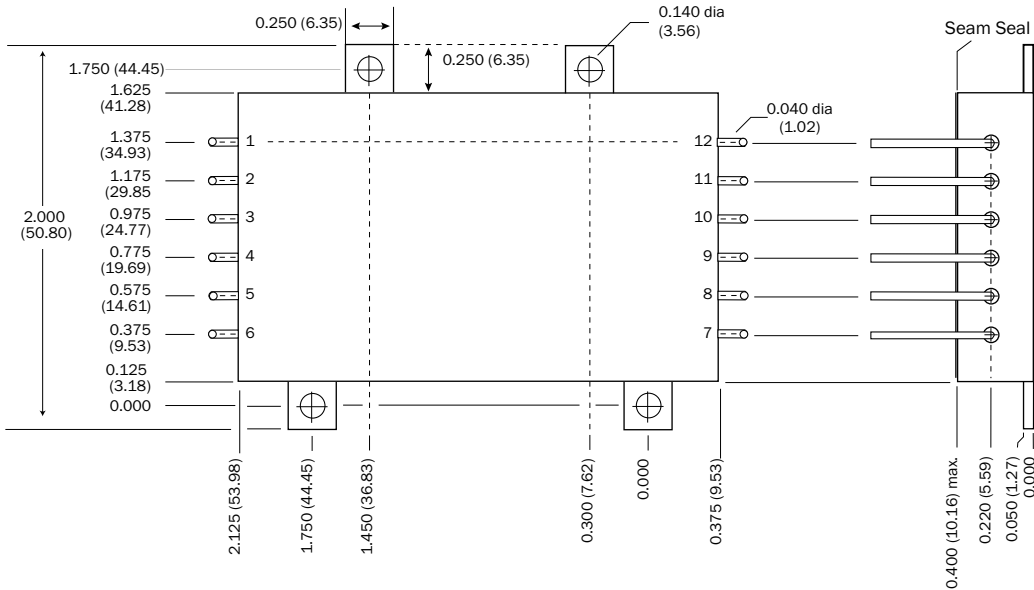

Weight: 86 grams maximum

Case dimensions in inches (mm)  
Tolerance  $\pm 0.005$  (0.13) for three decimal places  
 $\pm 0.01$  (0.3) for two decimal places  
unless otherwise specified

**CAUTION**  
Heat from reflow or wave soldering may damage the device. Solder pins individually with heat application not exceeding 300°C for 10 seconds per pin.

**Materials**  
Header Cold Rolled Steel/Nickel/Gold  
Cover Kovar/Nickel  
Pins OFHC copper/gold, compression glass seal  
Gold plating of 50 - 150 microinches  
Included in pin diameter  
Seal Hole: 0.120  $\pm$  0.002 (3.05  $\pm$  0.05)

Please refer to the numerical dimensions for accuracy.

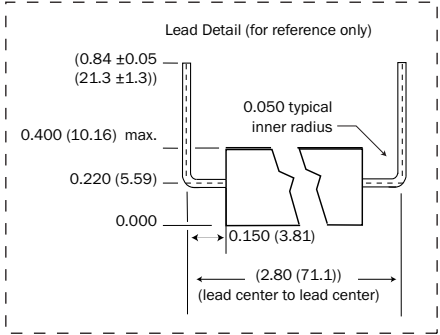

FIGURE 7: CASE W - FME270-461W



# FME270-461 EMI Input Filters

## 0 TO 400 VOLT INPUT – 1.5 AMP

Tabbed case, straight-leaded

Case "Y" requires a "Y" in the Case Option position of the model number.

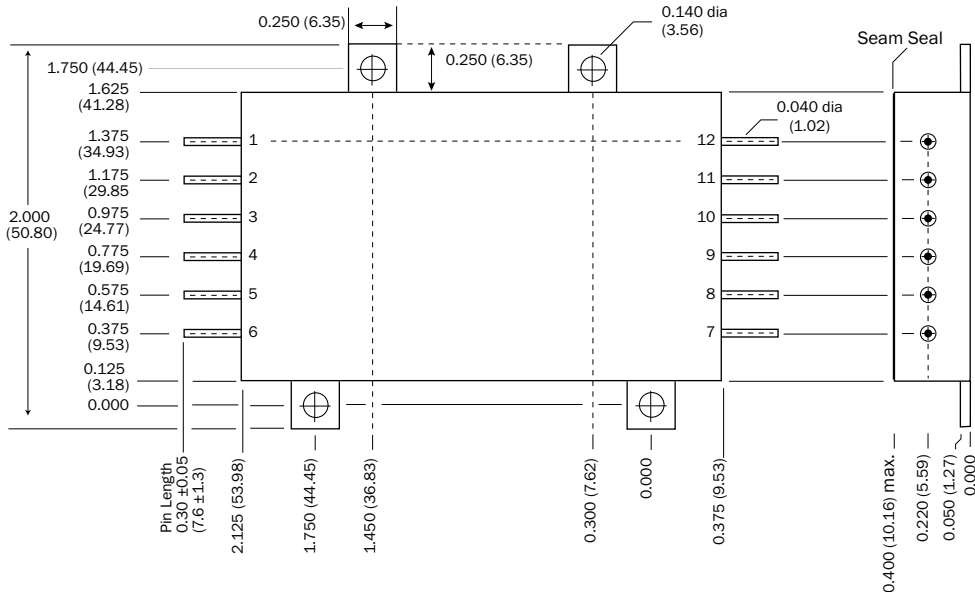

Weight: 86 grams maximum

Case dimensions in inches (mm)  
 Tolerance ±0.005 (0.13) for three decimal places  
 ±0.01 (0.3) for two decimal places  
 unless otherwise specified

**CAUTION**  
 Heat from reflow or wave soldering may damage the device. Solder pins individually with heat application not exceeding 300 °C for 10 seconds per pin.

- Materials**
- Header Cold Rolled Steel/Nickel/Gold
  - Cover Kovar/Nickel
  - Pins OFHC copper/gold, compression glass seal
  - Gold plating of 50 - 150 microinches
  - Included in pin diameter
  - Seal Hole: 0.120 ±0.002 (3.05 ±0.05)

Please refer to the numerical dimensions for accuracy.

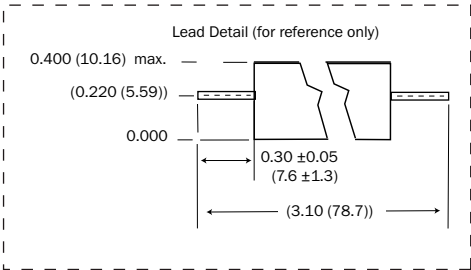

FIGURE 8: CASE Y - FME270-461Y

# FME270-461 EMI Input Filters

## 0 TO 400 VOLT INPUT – 1.5 AMP

TOP VIEW CASE Z  
Tabbed case, down-led

Case "Z" requires a "Z" in the Case Option position of the model number.

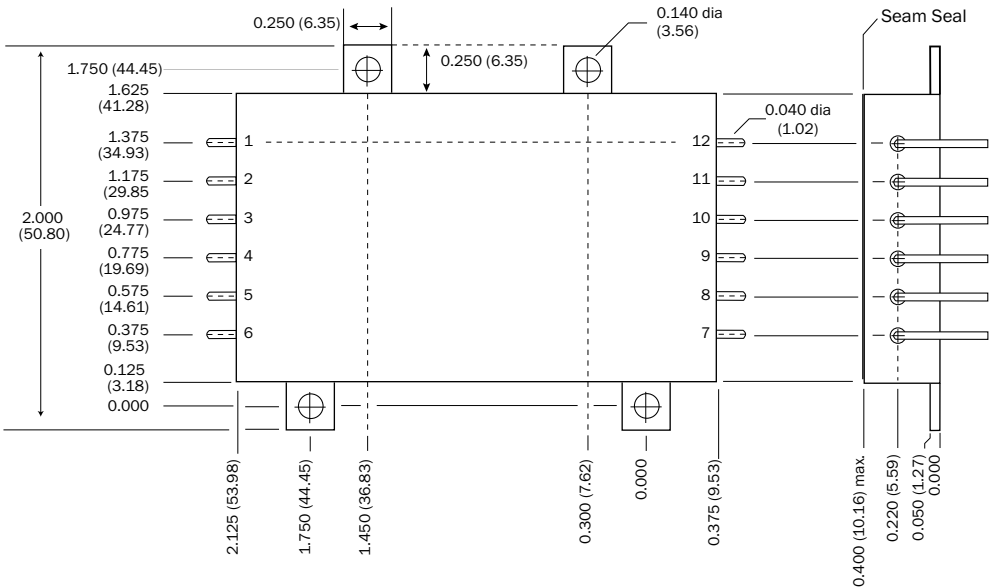

Weight: 86 grams maximum

Case dimensions in inches (mm)  
 Tolerance  $\pm 0.005$  (0.13) for three decimal places  
 $\pm 0.01$  (0.3) for two decimal places  
 unless otherwise specified

**CAUTION**  
 Heat from reflow or wave soldering may damage the device.  
 Solder pins individually with heat application not exceeding  
 300 °C for 10 seconds per pin.

**Materials**  
 Header Cold Rolled Steel/Nickel/Gold  
 Cover Kovar/Nickel  
 Pins OFHC copper/gold, compression glass seal  
 Gold plating of 50 - 150 microinches  
 Included in pin diameter  
 Seal Hole:  $0.120 \pm 0.002$  ( $3.05 \pm 0.05$ )

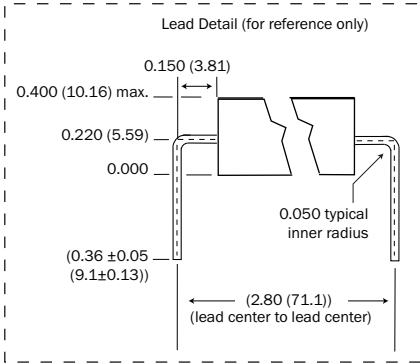

Please refer to the numerical dimensions for accuracy.

FIGURE 9: CASE Z - FME270-461Z

# FME270-461 EMI Input Filters

**0 TO 400 VOLT INPUT – 1.5 AMP**

## ENVIRONMENTAL SCREENING DC-DC CONVERTERS AND EMI FILTERS STANDARD AND /ES <sup>1</sup>

TEST PERFORMED	STANDARD	/ES
<b>Pre-cap Inspection</b> Method 2017, 2032	■	■
<b>Temperature Cycle (10 times)</b> Method 1010, Cond. B, -55°C to +125°C, ambient		■
<b>Constant Acceleration</b> Method 2001, 500 g		■
<b>Burn-in Method 1015 <sup>2</sup></b> 96 hours		■
<b>Final Electrical Test MIL-PRF-38534, Group A</b> Subgroups 1 and 4: +25°C case	■	■
<b>Hermeticity Test, Method 1014</b>  Gross Leak, Cond. C <sub>1</sub> , fluorocarbon  Fine Leak, Cond. A <sub>2</sub> , helium  Gross Leak, Dip		■
		■
	■	
<b>Final visual inspection</b> Method 2009	■	■

Test methods are referenced to MIL-STD-883 as determined by MIL-PRF-38534.

Notes

1. Standard and /ES products may not meet all of the requirements of MIL-PRF-38534.
2. Burn-in temperature designed to bring the case temperature to the maximum case temperature of the product. Refer to the specific product information for the maximum case temperature. Burn-in is a powered test.

TABLE 5: : ENVIRONMENTAL SCREENING

