

FMCE-0528 EMI Input Filters

-0.5 TO 50 VOLT INPUT – 5 AMP

FEATURES

- Attenuation 60 dB at 500 kHz, typical
- Operating temperature -55° to +125° C
- Nominal 28 volt input,
- -0.5 to 50 volt operation for FMCE-0528 ¹
- Transient rating -0.5 to 80 volt for 1 second FMCE-0528
- 5 amp throughput current
- Compliant to
- MIL-STD-461C CE03
- MIL-STD-461D, E and F CE102
- MIL-STD-461C CS01
- MIL-STD-461D, E, and F CS101
- Compatible with MIL-STD-704 A-E dc voltage transient surges. ¹



MODEL	CURRENT (A)
FMCE-0528-TR ¹	5
FMCE-0528 ¹	5

DESCRIPTION

The Interpoint® FMCE-0528™ EMI filters have been specifically designed to reduce the input line reflected ripple current of Interpoint MFK, MFX, MWR, MHV and MHF+ Series of DC-DC converters. The filter can be used with combinations of the lower power converters; up to two MTR series converters or a single MFL series converter up to the rated current of the filter. These filters are intended for use in 28 volt applications which must meet MIL-STD-461 levels of conducted emissions. The FMCE-0528 EMI filters provide up to 5 amps of throughput current in a low profile package. The filters are manufactured in our fully certified and qualified MIL-PRF-38534 Class H production facility and packaged in hermetically sealed steel cases. They are ideal for use in programs requiring high reliability and small size.

The FMCE-0528 filters are built using thick-film hybrid technology and are hermetically sealed in metal packages for military, aerospace, and other high-reliability applications. Only ceramic capacitors are used in the filters to ensure reliable high temperature operation.

The filters are offered with standard screening, “ES” screening, or fully compliant to “883” MIL-PRF-38534 Class H screening. A DLA Drawing is available, see Table 2 on page 3.

MIL-STD NOISE MANAGEMENT

When used in conjunction with Interpoint converters, the FMCE-0528 and FMCE-0528-TR filters reduce input ripple current within the frequency band of 100 kHz to 50 MHz. When used with an Interpoint converter, performance exceeds the CE03 test of MIL-STD-461C and meets the requirements of CS01 of MIL-STD-461C. These filters also meet CE102 and CS101 of MIL-STD-461D, E and F.

OPERATING TEMPERATURE

The filters are rated to operate, with no degradation of performance, over the temperature range of -55° C to +125° C (as measured at the baseplate). Above +125° C, current must be derated as specified in Table 4 on page 4. A DLA Drawing is available, see Table 2 on page 3.

INSERTION LOSS

Low dc resistance design results in a maximum power loss of less than 3% with typical input voltage.

LAYOUT REQUIREMENT

The case pin, and ideally the case, should be tied to the case of the converter through a low-inductance connection.

TRANSIENT SUPPRESSION - FMCE-0528-TR ONLY

The FMCE-0528-TR ¹ filter also features an optional fast-reacting (1 pico second) transient suppressor (transorb SMCG40A) which begins clamping the input voltage at approximately 47 volts, protecting the DC-DC converter from damage from induced line transients.

The FMCE-0528 ¹ does not have the transorb and is designed for those applications that require a wider input voltage range (-0.5 to 50 volts).

Note 1.

a) The FMCE-0528-TR has a transorb and will not protect against transients as defined in MIL-STD-704A Figures 8 and 9, curves 1 and 2. Operation beyond the defined specifications may damage the transorb.

b) The FMCE-0528 does not have a transorb and does not clamp the input voltage. Transients of higher than 40 volts will not harm the filter but will be passed to the converter.

FMCE-0528 EMI Input Filters

-0.5 TO 50 VOLT INPUT – 5 AMP

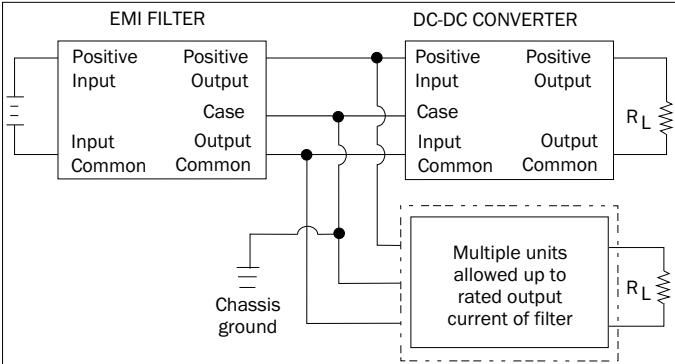

The case ground connection between the filter and the converter should be as low an impedance as possible to minimize EMI. Direct contact of baseplate to chassis ground provides the lowest impedance.

FIGURE 1: CONNECTION DIAGRAM

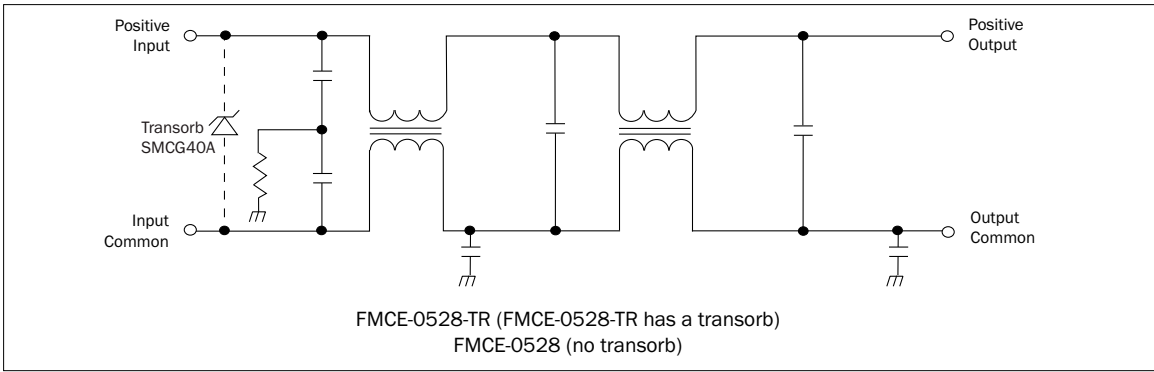
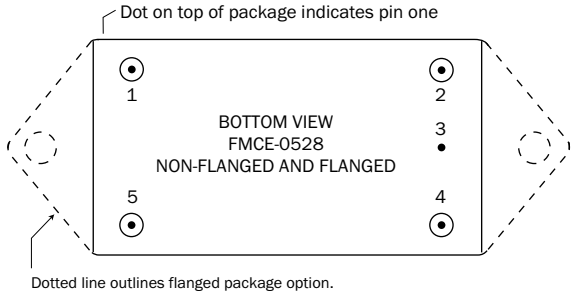

FIGURE 2: BLOCK DIAGRAM FMCE-0528

PIN OUT	
Pin 1	Designation
1	Positive Input
2	Positive Output
3	Case Ground
4	Output Common
5	Input Common

Notes
1. All pins must be connected.

TABLE 1: PIN OUT



Dotted line outlines flanged package option.
See Figure 10 on page 6 and Figure 11 on page 7 for dimensions.

FIGURE 3: PIN OUT

FMCE-0528 EMI Input Filters

-0.5 TO 50 VOLT INPUT – 5 AMP

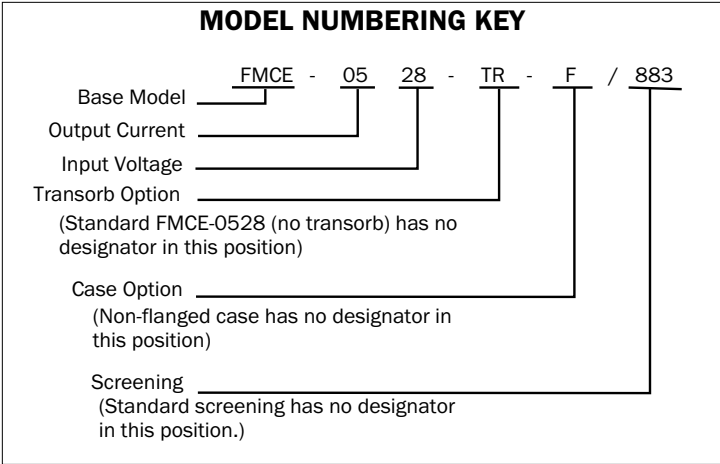

FIGURE 4: MODEL NUMBERING KEY

DLA NUMBERS	
DLA DRAWING (5915)	FMCE-0528 SIMILAR PART
10016-01HXC	FMCE-0528-TR/883 ¹
10016-01HZC	FMCE-0528-TR-F/883 ¹
10016-02HXC	FMCE-0528/883
10016-02HZC	FMCE-0528-F/883
1. Models with "TR" have a transorb (-01 in the DLA numbers). For exact specifications for a DLA product, refer to the DLA drawing. DLA drawings can be downloaded from: https://landandmaritimeapps.dla.mil/programs/smcr	

TABLE 2: DLA CROSS REFERENCE

MODEL NUMBER OPTIONS ¹				
To DETERMINE THE MODEL NUMBER ENTER ONE OPTION FROM EACH CATEGORY IN THE FORM BELOW.				
CATEGORY	Base Model and Input Voltage	Transorb ²	Case Option ³	Screening ⁴
OPTIONS	FMCE-0528	(no transorb, leave blank) -TR (with transorb)	(standard, leave blank) -F (Flanged)	(standard, leave blank) ES 883
FILL IN FOR MODEL # ⁵	FMCE-0528	_____	_____	/ _____
Notes 1. See Figure 4, above, for an example of a model number. 2. The FMCE-0528 does not have a transorb. The FMCE-0528-TR has a transorb for transient suppression (see page 1). 3. Case Options: For the standard case, Figure 10 on page 6, leave the case option blank. For the flanged case option, Figure 11 on page 7, insert the letter F in the Case Option position. 4. Screening: For standard screening leave the screening option blank. For other screening options, insert the desired screening level. For more information see Table 6 on page 8 and Table 7 on page 9. 5. If ordering by model number add a "-Q" to request solder dipped leads (FMCE-0528/883-Q).				

TABLE 3: MODEL NUMBER OPTIONS

FMCE-0528 EMI Input Filters

-0.5 TO 50 VOLT INPUT – 5 AMP

TABLE 4: OPERATING CONDITIONS: 28 VIN, UNLESS OTHERWISE SPECIFIED.

MODEL		FMCE-0528			UNITS
PARAMETER	CONDITIONS	MIN	TYP	MAX	
LEAD SOLDERING TEMPERATURE ¹	10 seconds max.	–	–	300	°C
STORAGE TEMPERATURE ¹		-65	–	+150	°C
CASE OPERATING TEMPERATURE ¹	FULL POWER	-55	–	+125	°C
	ABSOLUTE	-55	–	+135	
DERATING OUTPUT POWER/CURRENT ¹	LINEARLY	From 100% at 125°C to 0% at 135°C			
ESD RATING ^{1, 2}	MIL STD 883 METHOD 3015	–	–	≥8000	V
MIL-PRF-38534, 3.9.5.8.2	CLASS 3B				
ISOLATION, ANY PIN TO CASE EXCEPT CASE PIN	500 VDC AT 25°C	100	–	–	Megohms

Notes

1. Guaranteed by characterization test and/or analysis. Not a production test.
2. Passes 8000 volts.

TABLE 5: ELECTRICAL CHARACTERISTICS: -55°C TO +125°C CASE, 28 VIN, UNLESS OTHERWISE SPECIFIED.

MODEL		FMCE-0528-TR			FMCE-0528			UNITS
PARAMETER	CONDITIONS	MIN	TYP	MAX	MIN	TYP	MAX	
INPUT VOLTAGE ^{1, 2}	CONTINUOUS	-0.5	28	40	-0.5	28	50	V
	TRANSIENT 50 MS ³	–	47	–	–	–	80	
INPUT CLAMPING VOLTAGE ⁴	T _C = -55°C	40.8	45.1	49.4	–	–	–	V
	T _C = 25°C	44.7	47.0	49.4	–	–	–	
	T _C = 125°C	44.7	49.5	54.2	–	–	–	
NOISE REJECTION	500 KHZ	55	60	–	55	60	–	dB
DIFFERENTIAL NOISE	1 MHZ	60	–	–	60	–	–	
DC RESISTANCE (R _{DC})	T _C = 25°C	–	–	0.13	–	–	0.13	Ω
CAPACITANCE 25°C	ANY PIN TO CASE EXCEPT CASE PIN	–	44,000	48,000	–	44,000	48,000	pF
OUTPUT VOLTAGE ^{1, 5}	STEADY STATE	$V_{OUT} = V_{IN} - I_{IN} (R_{DC})$			$V_{OUT} = V_{IN} - I_{IN} (R_{DC})$			V
OUTPUT CURRENT ¹	STEADY STATE	–	–	5	–	–	5	A
POWER DISSIPATION ¹	T _C = 25°C	–	2.8	3.0	–	2.8	3.1	W
	T _C = 125°C	–	–	3.8	–	–	3.8	

Notes

1. Guaranteed by characterization test and/or analysis. Not a production test.
2. Transients:
 - a) The FMCE-0528-TR has a transorb and will not protect against transients as defined in MIL-STD-704A Figures 8 and 9, curves 1 and 2. Operation beyond the defined specifications may damage the transorb. It will begin to clamp the voltage at approximately 47 volts.
 - b) The FMCE-0528 does not have a transorb and does not clamp the input voltage. Transients of higher than 40 volts will not harm the filter but will be passed to the converter.
3. 0.5 ohm source impedance
4. The FMCE-0528 does not have a transorb and does not clamp the input voltage.
5. Typical applications result in V_{OUT} within 2% of V_{IN}.

FMCE-0528 EMI Input Filters

-0.5 TO 50 VOLT INPUT - 5 AMP

TYPICAL PERFORMANCE PLOTS: 25 °C CASE, UNLESS OTHERWISE SPECIFIED.

FOR REFERENCE ONLY, NOT GUARANTEED SPECIFICATIONS.

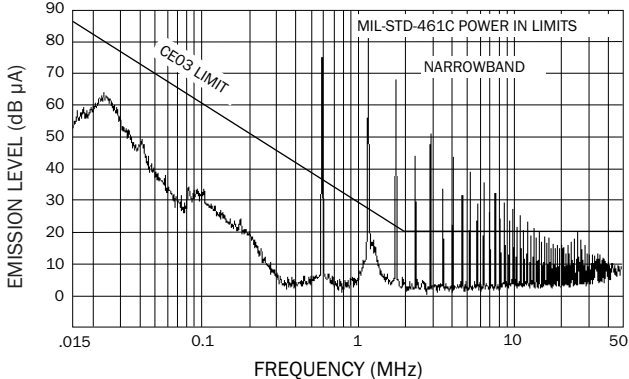

High power DC-DC converter without filtering.

FIGURE 5

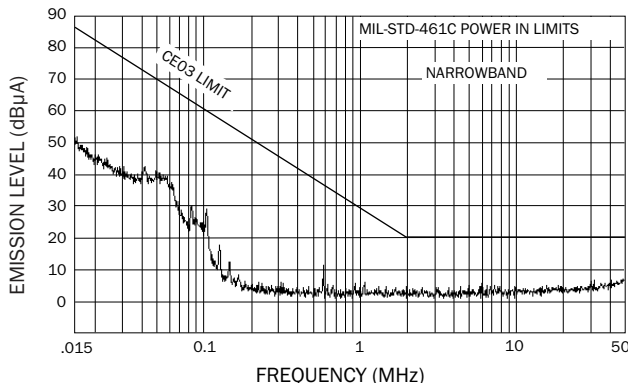

CE03: High power DC-DC converter filtered with an FMCE-0528

FIGURE 6

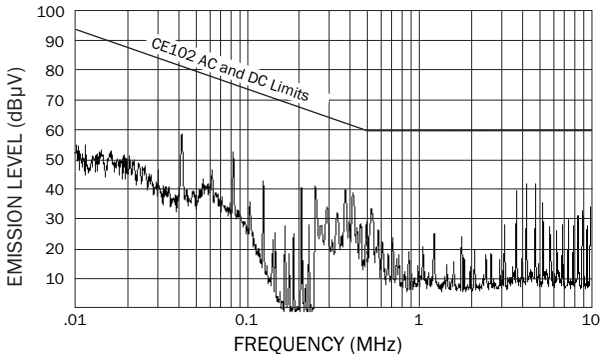

CE102: High power converter filtered with an FMCE-0528.

FIGURE 7

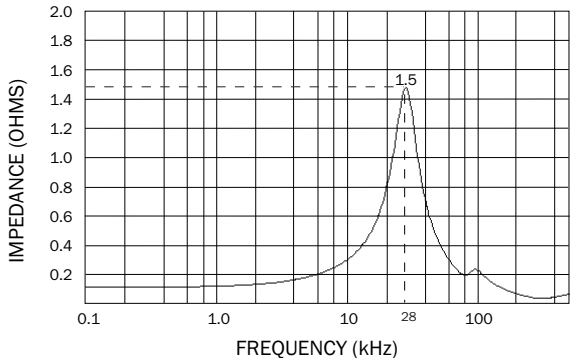

FMCE-0528 Output Impedance (measured at the output with input pins shorted)

FIGURE 8

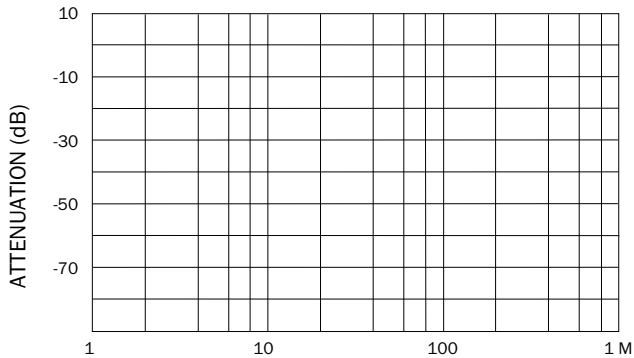

FMCE-0528 Attenuation

FIGURE 9

FMCE-0528 EMI Input Filters

-0.5 TO 50 VOLT INPUT - 5 AMP

BOTTOM VIEW CASE H1

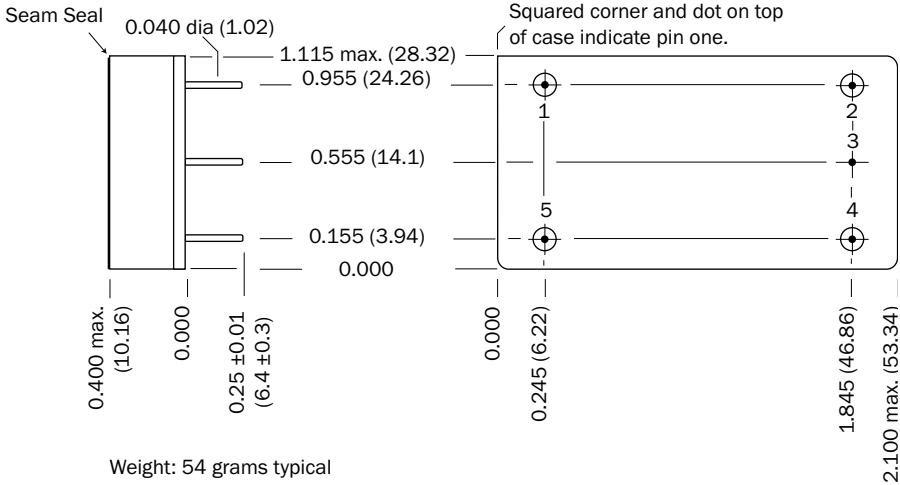

Weight: 54 grams typical

Case dimensions in inches (mm)
Tolerance ±0.005 (0.13) for three decimal places
±0.01 (0.3) for two decimal places
unless otherwise specified

CAUTION
Heat from reflow or wave soldering may damage the device.
Solder pins individually with heat application not exceeding 300°C for 10 seconds per pin

Materials
Header Cold Rolled Steel/Nickel/Gold
Cover Kovar/Nickel
Pins #52 alloy/Gold, ceramic seal
Seal hole 0.120 ±0.002 (3.05 ± 0.05)

Please refer to the numerical dimensions for accuracy.

FIGURE 10: CASE H1

FMCE-0528 EMI Input Filters

-0.5 TO 50 VOLT INPUT – 5 AMP

BOTTOM VIEW CASE K2

Flanged cases: Designator "F" required in Case Option position of model number.

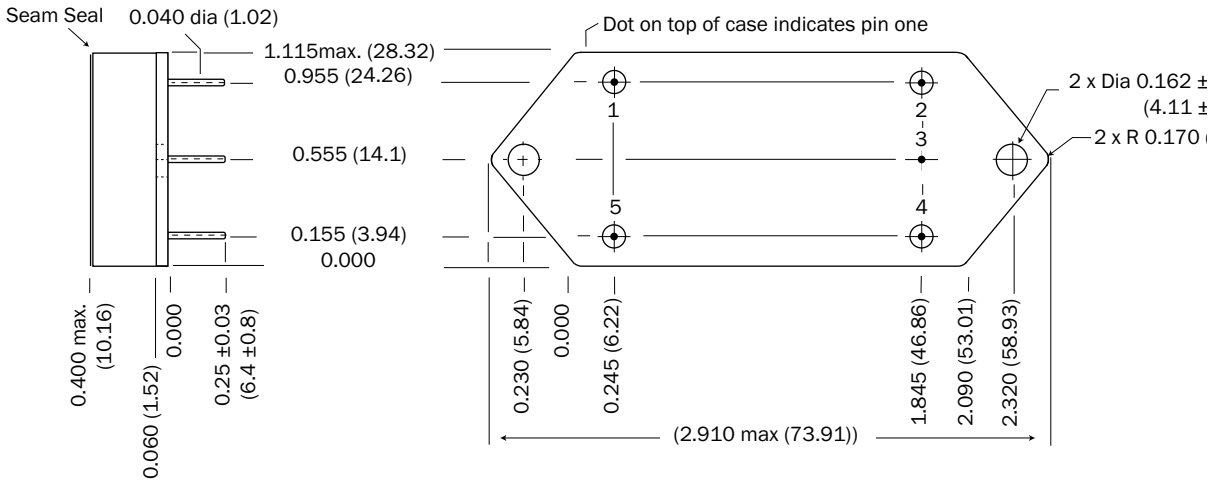

Weight: 54 grams typical

Case dimensions in inches (mm)
Tolerance ±0.005 (0.13) for three decimal places
±0.01 (0.3) for two decimal places
unless otherwise specified

CAUTION
Heat from reflow or wave soldering may damage the device. Solder pins individually with heat application not exceeding 300°C for 10 seconds per pin.

Materials
Header Cold Rolled Steel/Nickel/Gold
Cover Kovar/Nickel
Pins #52 alloy/Gold, ceramic seal.
Seal Hole: 0.120 ±0.002 (3.05 ±0.05)

Please refer to the numerical dimensions for accuracy.

FIGURE 11: CASE K2

FMCE-0528 EMI Input Filters

-0.5 TO 50 VOLT INPUT – 5 AMP

ELEMENT EVALUATION ¹ HIGH RELIABILITY DC-DC CONVERTERS AND EMI FILTERS /883 (CLASS H)

COMPONENT-LEVEL TEST PERFORMED	QML	
	CLASS H /883	
	M/S ²	P ³
Element Electrical	■	■
Visual	■	■
Internal Visual	■	
Final Electrical	■	■
Wire Bond Evaluation	■	■

Notes

- 1. Element evaluation does not apply to standard and /ES product.
- 2. M/S = Active components (microcircuit and semiconductor die).
- 3. P = Passive components, Class H element evaluation. Not applicable to standard and /ES element evaluation.

TABLE 6: ELEMENT EVALUATION

FMCE-0528 EMI Input Filters

-0.5 TO 50 VOLT INPUT – 5 AMP

ENVIRONMENTAL SCREENING HIGH RELIABILITY DC-DC CONVERTERS AND EMI FILTERS STANDARD, /ES AND /883 (CLASS H)

TEST PERFORMED	NON-QML ¹		CLASS H QML ²
	STANDARD	/ES	/883 QML ³
Pre-cap Inspection, Method 2017, 2032	■	■	■
Temperature Cycle (10 times)			■
Method 1010, Cond. C, -65°C to +150°C, ambient			■
Method 1010, Cond. B, -55°C to +125°C, ambient		■	
Constant Acceleration			■
Method 2001, 3000 g			■
Method 2001, 500 g		■	
PIND, Test Method 2020, Cond. A			■ ⁴
Burn-in Method 1015, +125°C case, typical ⁵			
96 hours		■	
160 hours			■
Final Electrical Test, MIL-PRF-38534, Group A,			■
Subgroups 1 through 6, -55°C, +25°C, +125°C case			■
Subgroups 1 and 4, +25°C case	■	■	
Hermeticity Test, Method 1014			
Gross Leak, Cond. C ₁ , fluorocarbon		■	■
Fine Leak, Cond. A ₂ , helium		■	■
Gross Leak, Dip	■		
Final visual inspection, Method 2009	■	■	■

Test methods are referenced to MIL-STD-883 as determined by MIL-PRF-38534.

Notes

1. Non-QML products may not meet all of the requirements of MIL-PRF-38534.
2. All processes are QML qualified and performed by certified operators.
3. Class H QML products have an SMD number
4. Not required by DLA but performed to assure product quality.
5. Burn-in temperature designed to bring the case temperature to +125°C minimum. Burn-in is a powered test.

TABLE 7: ENVIRONMENTAL SCREENING

