

I&Q Network - IQF-20F-1575 SQ

TECHNICAL FEATURE

FEATURES

- Space Qualified
- Precision Phase and Amplitude Balance
- Hi-Rel Flatpack

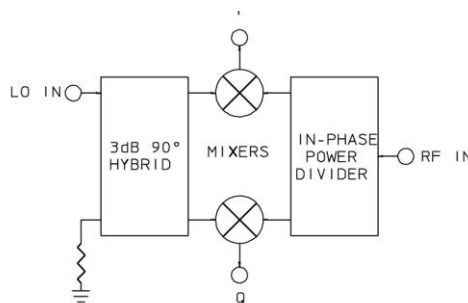

PERFORMANCE

| | |
|-------------------------------------|--------------------|
| LO Frequency | 1575 MHz |
| RF Frequency | 1575 ± 78.8 MHz |
| LO Power Level | +10 dB nom. |
| RF Power Level | 0 dB nom. |
| VSWR RF/LO | 1.5:1 max. |
| Conversion Loss | 12 dB max. |
| Phase Balance @ LO=fo | ±2° max. |
| Phase Balance @ LO=fo ±5% | ±5° max. |
| Amplitude Balance @ LO=fo | ±0.2dB max. |
| Amplitude Balance @ LO=fo ±5% | ±0.5dB max. |
| Weight | 0.35 oz (10g) nom. |
| Operating Temperature | -55° to +85° C |

DESCRIPTION

I & Q Networks are integrated devices that produce two quadrature-phased equal amplitude signals when fed RF and LO signals. In the IQF Series, specially optimized circuits are used to provide superior performance across very wide bandwidths and high data rates. This unit has been designed, manufactured and qualified per Merrimac document CENG-0001, "Standard Design Requirements for Space Qualified Devices".

PACKAGE OUTLINE

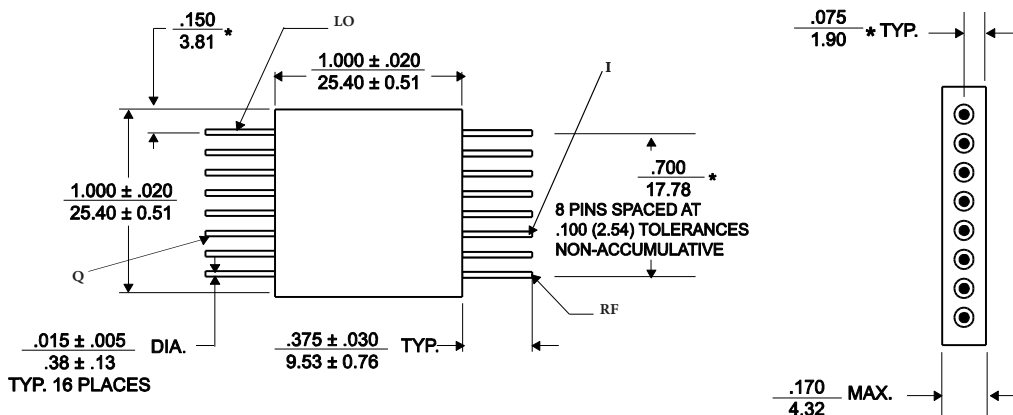

- NOTES:**
1. Tolerance on 3 place decimals ± .010(.25) except as noted.
 2. Dimensions in inches over millimeters.
 3. Dimensions marked with * apply only at body.
 4. All unmarked pins are case ground.

Crane Aerospace & Electronics
 Microwave Solutions – Merrimac Industries
 41 Fairfield Place, West Caldwell, NJ 07006
 + 1.973.575.1300 ext. 1309 • mw@crane-eg.com
 www.craneae.com/mw

IQF-20F-1575 SQ



DS_IQ Modulator_IQF20F1575SQ_02182025. This revision supersedes all previous releases. All technical information is believed to be accurate, but no responsibility is assumed for errors. We reserve the right to make changes in products or specifications without notice. Copyright © 2025 Crane Electronics, Inc. All rights reserved.