

### TECHNICAL FEATURE

#### FEATURES

- Space Qualified
- 19.7 - 20.7 GHz
- 2 x 4 - Way

### PRINCIPAL SPECIFICATIONS

Model Number	Frequency Range GHz	Isolation dB Min.	Insertion Loss, dB Max.	Phase Balance Max.	Amplitude Balance dB Max.	VSWR Max.		CW Input, W, Load VSWR out 1.2:1	Weight Max.
						In	Out		
PDM-241-20.2G SQ	19.7 - 20.7	18	1.2	6°	0.3	1.22:1	1.22:1	1	87 g.

### TECHNICAL DESCRIPTION / APPLICATION

The PDM-241-20.2G SQ In-Phase Power Divider covers 19.7 - 20.7 GHz. It uses a stripline design which provides high isolation and low VSWR. This unit has been designed, manufactured, and qualified per Merrimac document CENG-0001, "Standard Design Requirements for Space Qualified Devices."

### PACKAGE OUTLINE

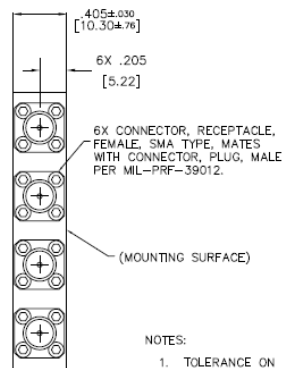
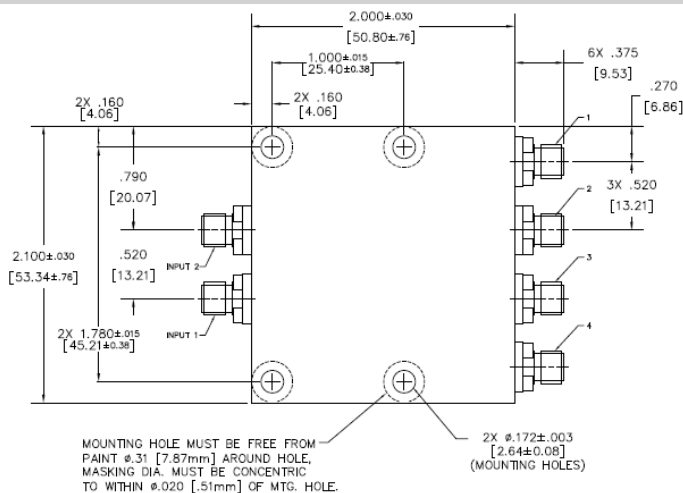

#### NOTES:

1. TOLERANCE ON 3 PLACE DECIMALS ±.020 [.51mm], EXCEPT WHERE NOTED.
2. MAX. IS LARGEST DIMENSION ALLOWED.
3. DIMENSIONS = INCHES [mm]
4. METRIC EQUIVALENTS ARE TO THE NEAREST .01mm
5. EXTERNAL FINISH:  
EXTERIOR SURFACES: FLAT BLACK POLYURETHANE COATING AEROGLAZE Z306 (EXCEPT MOUNTING SURFACE TOP MOUNTING HOLE AREA AND AREA AROUND VENT HOLES AND VENT SLOT). MOUNTING AND UNPAINTED SURFACE FINISH: CHEMICAL FILM PER MIL-DTL-5541, CLASS 3. CONNECTOR FINISH: PASSIVATED.
6. WEIGHT: 3.07 OZ. [87g] MAX.