

TECHNICAL FEATURE

FEATURES

- Space Qualified
- 10.95 - 12.75 GHz
- 2 x 4 - Way

PRINCIPAL SPECIFICATIONS

Model Number	Frequency Range GHz	Isolation dB Min.	Insertion Loss, dB Max.	Phase Balance Max.	Amplitude Balance dB Max.	VSWR Max.		CW Input, W, Load VSWR out 1.2:1	Weight Max.
						In	Out		
PDM-241-11.85G SQ	10.95 - 12.75	20	0.8	6°	0.3	1.29:1	1.29:1	1	87 g.

TECHNICAL DESCRIPTION / APPLICATION

The PDM-241-11.85G SQ In-Phase Power Divider covers 10.95 - 12.75 GHz. It uses a stripline design which provides high isolation and low VSWR. This unit has been designed, manufactured, and qualified per Merrimac document CENG-0001, "Standard Design Requirements for Space Qualified Devices."

PACKAGE OUTLINE

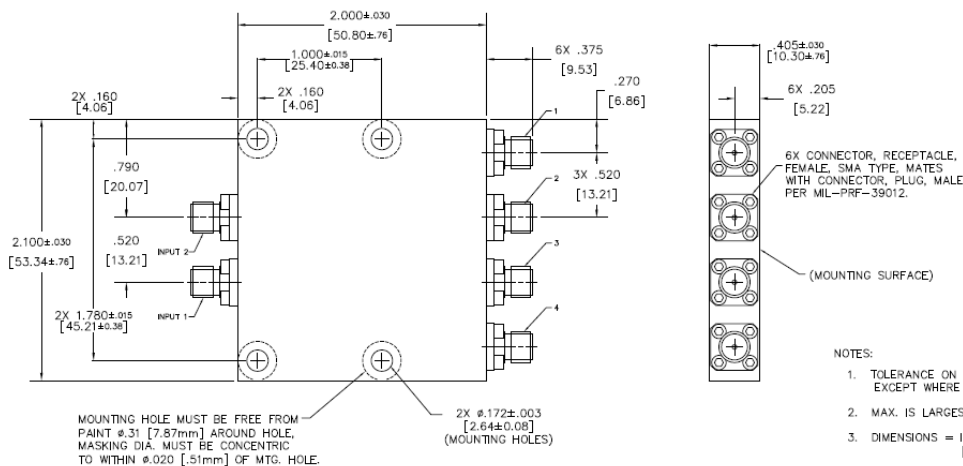

- NOTES:
1. TOLERANCE ON 3 PLACE DECIMALS ± 0.20 [.51mm] EXCEPT WHERE NOTED.
 2. MAX. IS LARGEST DIMENSION ALLOWED.
 3. DIMENSIONS = INCHES [mm]
 4. METRIC EQUIVALENTS ARE TO THE NEAREST .01mm
 5. EXTERNAL FINISH:
EXTERIOR SURFACES: FLAT BLACK POLYURETHANE COATING
AEROGLAZE Z306 (EXCEPT MOUNTING SURFACE TOP MOUNTING HOLE AREA AND AREA AROUND VENT HOLES AND VENT SLOT).
MOUNTING AND UNPAINTED SURFACE FINISH:
CHEMICAL FILM PER MIL-DTL-5541, CLASS 3.
CONNECTOR FINISH: PASSIVATED.
 6. WEIGHT: 3.07 OZ. [87g] MAX.