

Transient Suppression: Switching Power Supplies

INTERPOINT® APPLICATION NOTE

Although the concepts stated are universal, this application note was written specifically for Interpoint products.

Power line transient requirements are a subject which should be addressed at the beginning of a project, not in the later stages. If delayed until later there may not be enough room left for a good solution. When the time comes, two very important questions should be asked:

1. What is the transient source impedance? Inquire about both the real & imaginary parts.
2. What is the volt-second product of the transient?

If the answer is a large source impedance and a small volt-second product, the problem will be simple to solve. If the volt-second product is large and the source impedance low, the usual case, the solution will be more difficult.

The following is written around a 28 volt dc power bus, where positive transients should be contained within the 35 to 50 volt area, where the maximum long term transient rating for many power converters is 50 volts. For power converters which have an 80 volt long term transient rating, suppression to less than say 70 volts will provide margin, but the output response of the power supply will most likely not be specified.

The means which are available to suppress voltage transients are listed in the following:

1. Transient voltage suppressor (TVS), metal oxide varistor (MOV). This is a brute force approach.
2. Shunt capacitors. Will work with a high source impedance.
3. Series inductor. Absorbs the voltage and limits the di/dt.
4. Buck regulator for lower voltage, longer term transients.
5. Stripper. Allows the nominal 28 volt bus voltage to pass through under normal operation, and becomes a series regulator to maintain a lower level voltage during the transient duration.
6. Combinations of 1, 2, and 3 above.

Figure 1 shows the functional schematic of a switching power supply with some of the various means of transient suppression shown at its input. The switching power supply has an incrementally negative input impedance which must be considered before inserting any suppression network in series with its input. The negative input Z is due to the constant power input, with a constant load, as a function line voltage. Simply stated, $V_{IN} \times I_{IN} = K$, a constant with a fixed load and $I_{IN} = K/V_{IN}$. The increasing input current with a decreasing input voltage defines a hyperbola, the slope at the operating point being the negative Z . The converter's input current is highest and its input impedance is the lowest at the lowest input voltage.

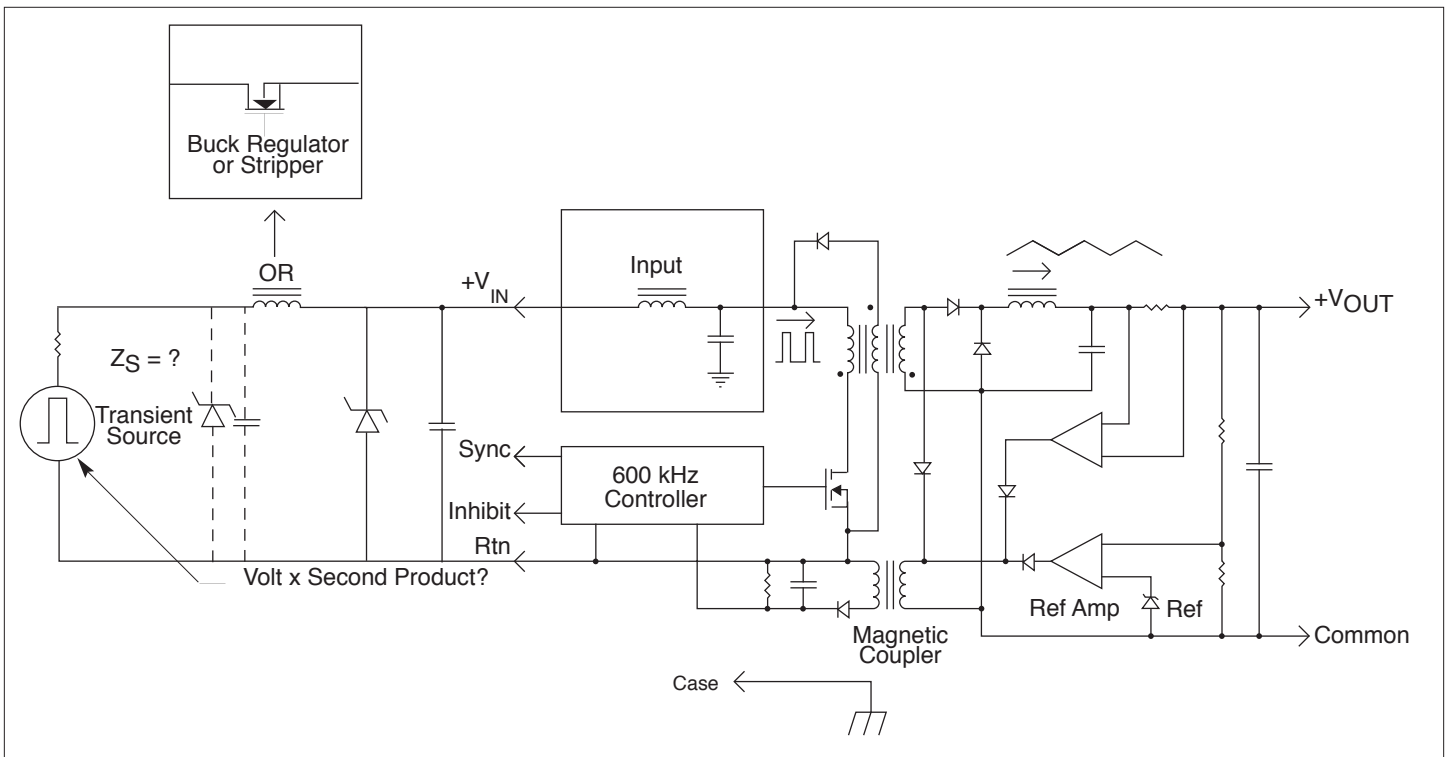

FIGURE 1: TRANSIENT SUPPRESSION FOR A SWITCHING POWER SUPPLY

Transient Suppression: Switching Power Supplies

INTERPOINT® APPLICATION NOTE

For stable operation, and to prevent possible rail to rail oscillation of the converter's input voltage, the impedance looking back to the dc source, which includes any transient suppression network, must be less than the impedance seen looking into the switching power converter. Even if a converter does not need to operate at low line, where its lowest impedance occurs, the converter can turn on and operate at lower voltages during a slow rising input voltage during power up. Keeping the converter off, via the inhibit function, until the input voltage is up and stable can alleviate this situation.

The converter's negative impedance is what causes the converter's input voltage to oscillate. The converter's negative input impedance is caused by the converter's high loop gain and its feed-forward compensation. Consult our "EMI Conducted Interference" app note for more details regarding this. It may also be advisable to consult one of the Interpoint Applications Engineers before finalizing any suppression network design. Also, refer to Figure 2 and Figure 3 which have additional information.

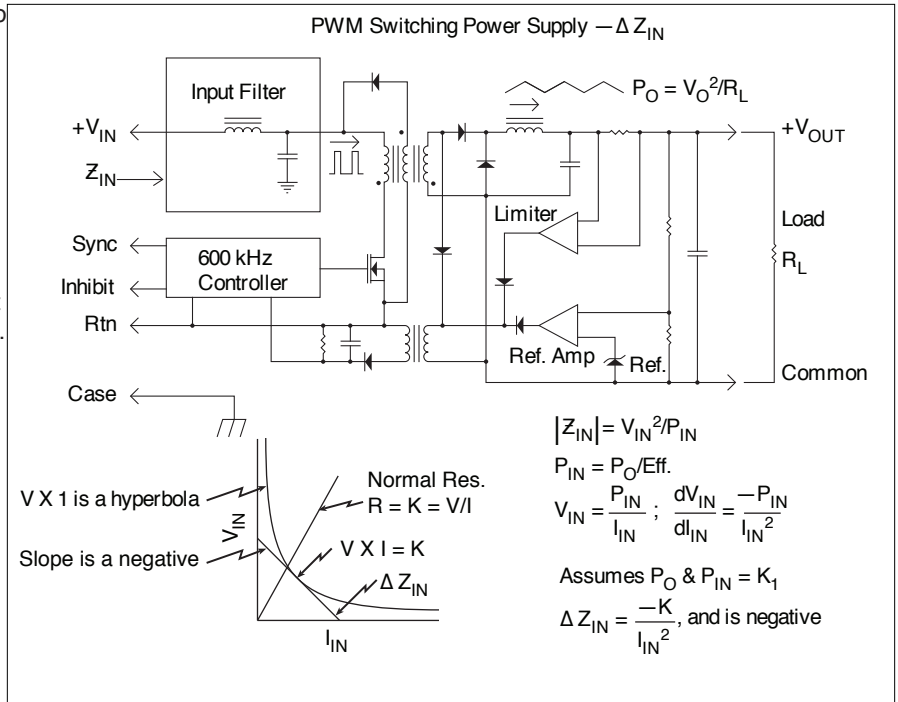

FIGURE 2: NEGATIVE Z_{IN}

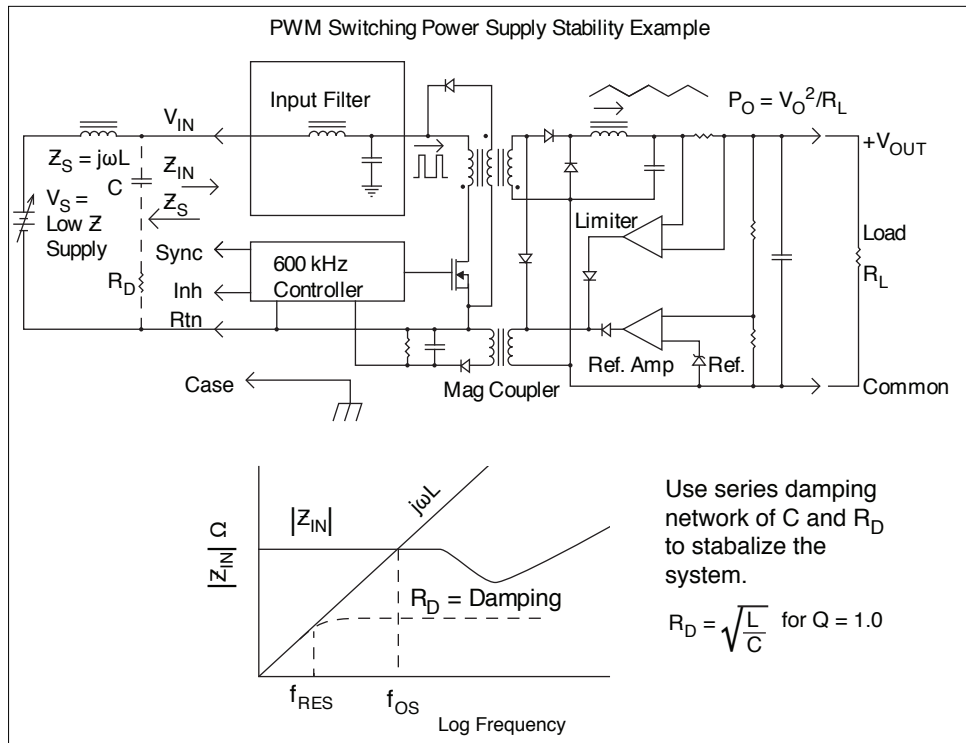

FIGURE 3: DAMPING FOR STABILITY

Transient Suppression: Switching Power Supplies

INTERPOINT® APPLICATION NOTE

SHORT TERM TRANSIENTS

Figure 4 and Figure 5 show typical transient waveforms taken from DO-160C and MIL-STD-461C. The Figure 4 waveform is an approximated damped half sine with a peak of 600 volts and a half period of 10 μ s. The 50 ohm source impedance allows it to be suppressed with a shunt capacitor or TVS across the 28 volt line.

In either case the peak suppression current will not exceed 12 amps (600 volts/50 ohms). Using a 600 volt rectangular pulse for simplicity, a 10 μ F low equivalent series resistance (ESR) capacitor placed in shunt with the line will reduce the peak transient response to about 12 volts on top of the 28 volt power line.

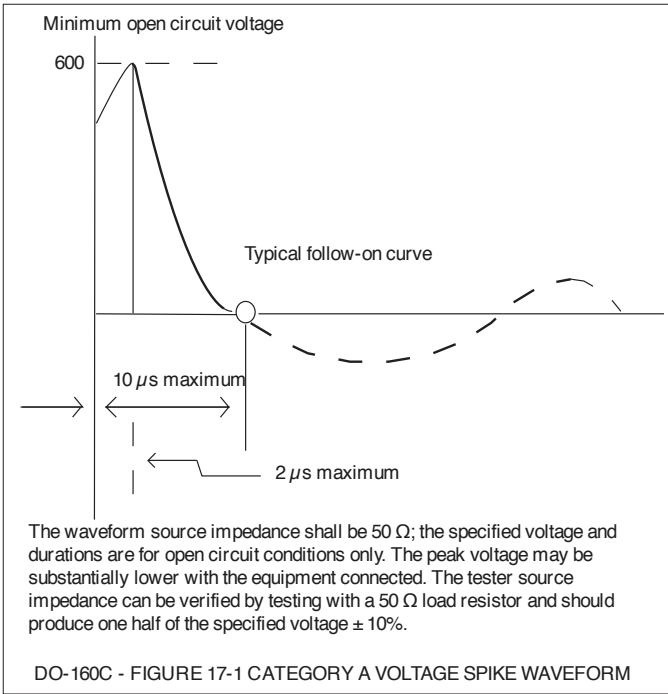

FIGURE 4: TYPICAL TRANSIENTS – DO-160C

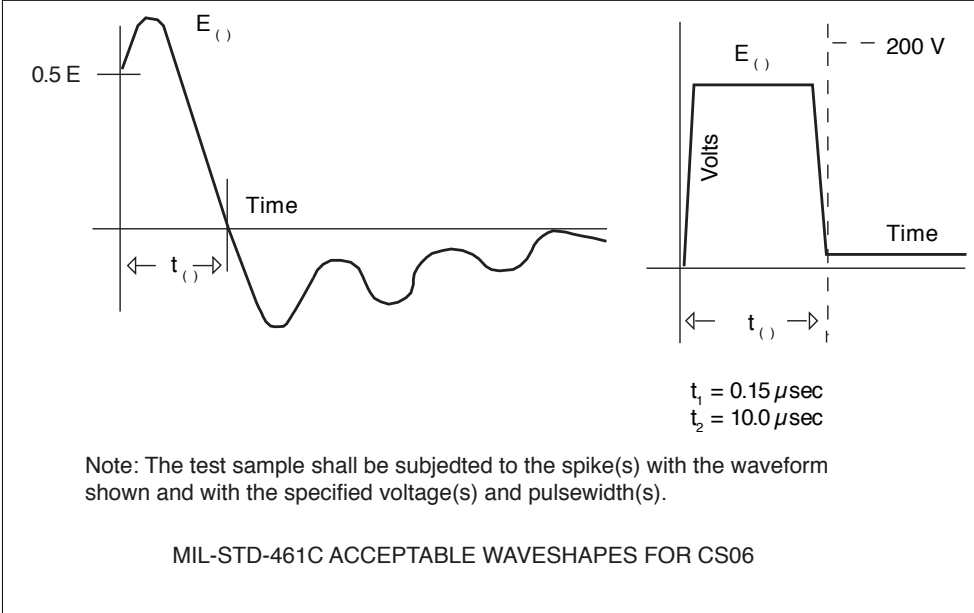

FIGURE 5: TYPICAL TRANSIENTS – CS06

Transient Suppression: Switching Power Supplies

INTERPOINT® APPLICATION NOTE

Refer to Figure 6 for the model and simulation results. It is important to ensure that the capacitor chosen can take the high surge currents. A TVS will also work in place of, or with, the capacitor. A suitable surface mount device is SMCJ30A from Microsemi Corp. This device should clamp the line at about 40 volts depending on the current. The SMCJ30A also has a forward rating of 200 amps for 1/120 of a second which would be useful for suppressing negative transients, if any. Other higher power TVS devices are also available. When considering reverse voltages, it is important to understand that the TVS will be used at the front end of a converter and the converter's main switching MOSFET will be in parallel with the TVS. Any reverse current may also pass through the body diode of the converter's MOSFET which may damage the converter. A forward rectifier in series with the positive line can be used to block any reverse current.

The MIL-STD-461C transient of Figure 5 has a low source impedance and will be harder to suppress than the previous case. Unless defined otherwise, the source impedance should be assumed to be zero. A value of 0.5 ohms is often allowed for testing. For the purpose of analysis, a value of 0.1 ohms is used.

The 0.15 μs , 200 volt rectangular transient could be suppressed with a low ESR ceramic capacitor, or a TVS. However, the transient line current would be very large. Adding a small series inductor will reduce the current to a manageable level. Since most of the transient voltage will appear across the inductor, the rate at which the current rises will be V/L , where V is the transient peak voltage, L is the inductance in henries, and the rate is in amps/second. If we limit the peak current to 10 amps, the inductance = $(V)(t)/(10)$ or greater, where V is the 200 volt transient, t is the pulse duration of 0.15 μs and 10 is the current in amps. The calculated inductance is 3 μH .

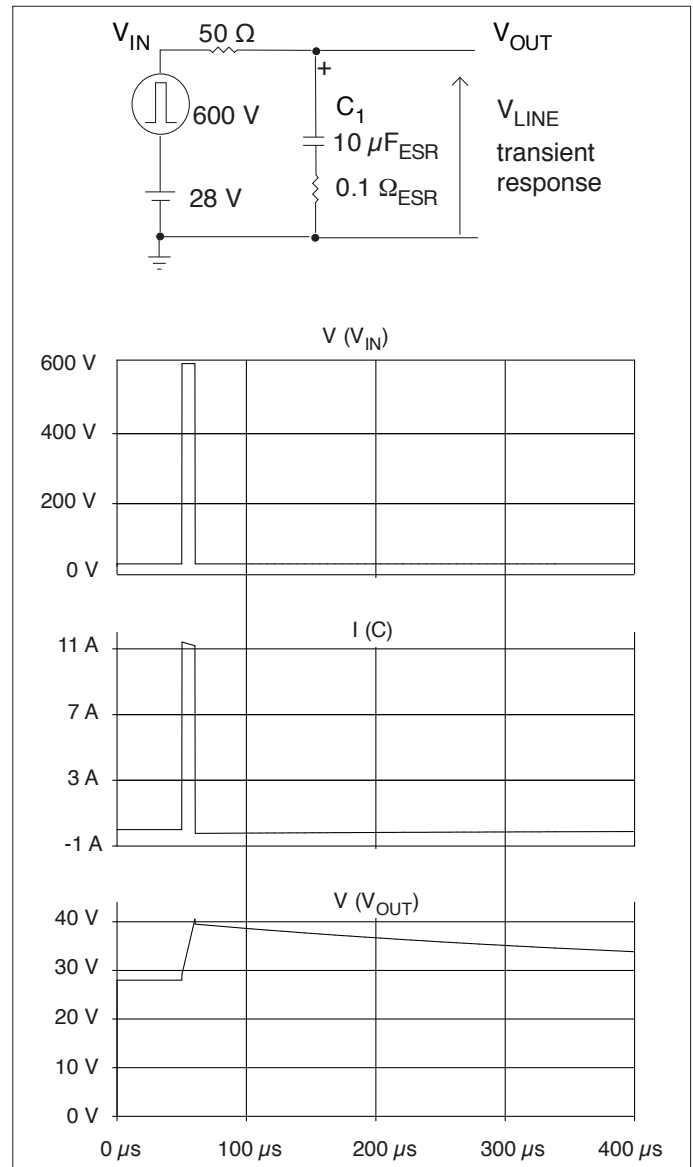

FIGURE 6: TRANSIENT RESPONSE

Transient Suppression: Switching Power Supplies

INTERPOINT® APPLICATION NOTE

Either a shunt capacitor or transorb can be used for the small value inductor to work against. In this case we will use a $10\ \mu\text{F}$ capacitor forming a resonant circuit with the inductor. A damping resistor in series with the capacitor should be used to minimize the driving point impedance ($\sqrt{L/C}$) and create a low Q. Using Spice to optimize the Q we find that a 1 ohm damping resistor results in a Q of less than 1.2. See Figure 7 for the model and simulation results showing the Q of the filter. The 1 ohm resistor is added in series with the $10\ \mu\text{F}$ capacitor, and should include any capacitor ESR. If the capacitor has significant ESR the damping resistor may need to be decreased so the combined resistance is close to 1 ohm. Ideally the added resistor is much larger than the capacitor ESR so that the added resistor dominates and swamps out variations in the capacitor ESR. The capacitor and resistor should also be able to handle the surge current during any transients and any power dissipation if a CS01 type of test is required. Any additional circuitry can change the Q of the circuit and should be added to the model.

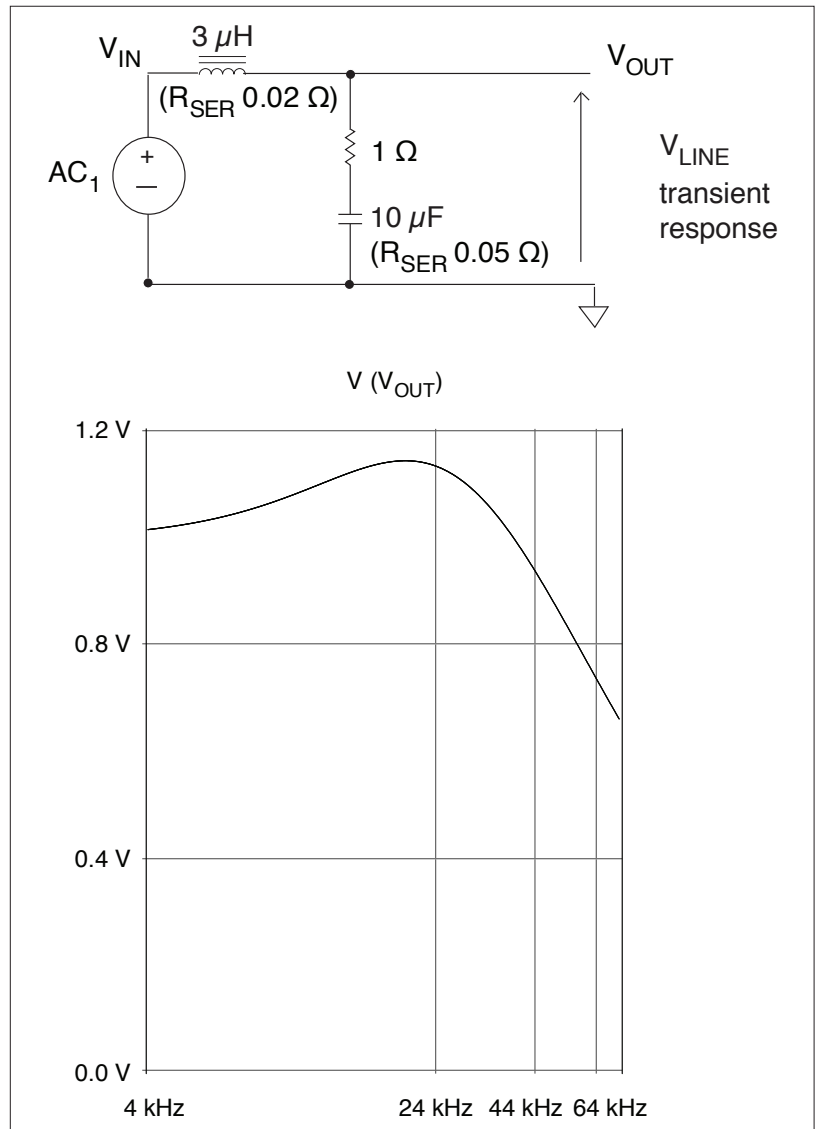

FIGURE 7: TRANSIENT RESPONSE

Transient Suppression: Switching Power Supplies

INTERPOINT® APPLICATION NOTE

In addition ensure the impedance looking back to the dc source (source impedance) is minimized to prevent impedance problems. The model and simulation of the source impedance are shown in Figure 8. Since the model uses a 1 amp current source the voltage scale translates to ohms as $I \times Z = V$ and I is equal to 1 amp. The simulation results show the impedance is slightly greater than 1 ohm which will be fine for most applications up to around 75 watts and assuming a low line input voltage of around 16 volts. Any other circuitry in the path to the dc source, including the converter's input filter, and the impedance of the dc source itself should be added to the model. For our model we assume a dc source impedance of zero ohms and replaced it with a short. In many cases a short is the worst case as any additional resistance can help lower the resonant impedance of LC circuits. The impedance issue is mainly a concern within the converter's bandwidth.

The inductor has to carry not only the transient capacitor current, but also the current drawn by the converter. It is important to account for any decrease in inductance due to the current flowing through the inductor. Let's consider a sample design using a 0.38" diameter, 0.156" height, 26 μ , High Flux toroid from Magnetics. The Magnetics part number of the core is 58292. The High Flux material is a good choice for high bias currents. 15 turns are needed to achieve 3 μ H with this core. 15 turns of # 24 AWG wire create a DC resistance of about 0.02 ohms at 25°C. The formulas for inductance and magnetizing force, in ampere turns/cm are given below for those who want to try it themselves.

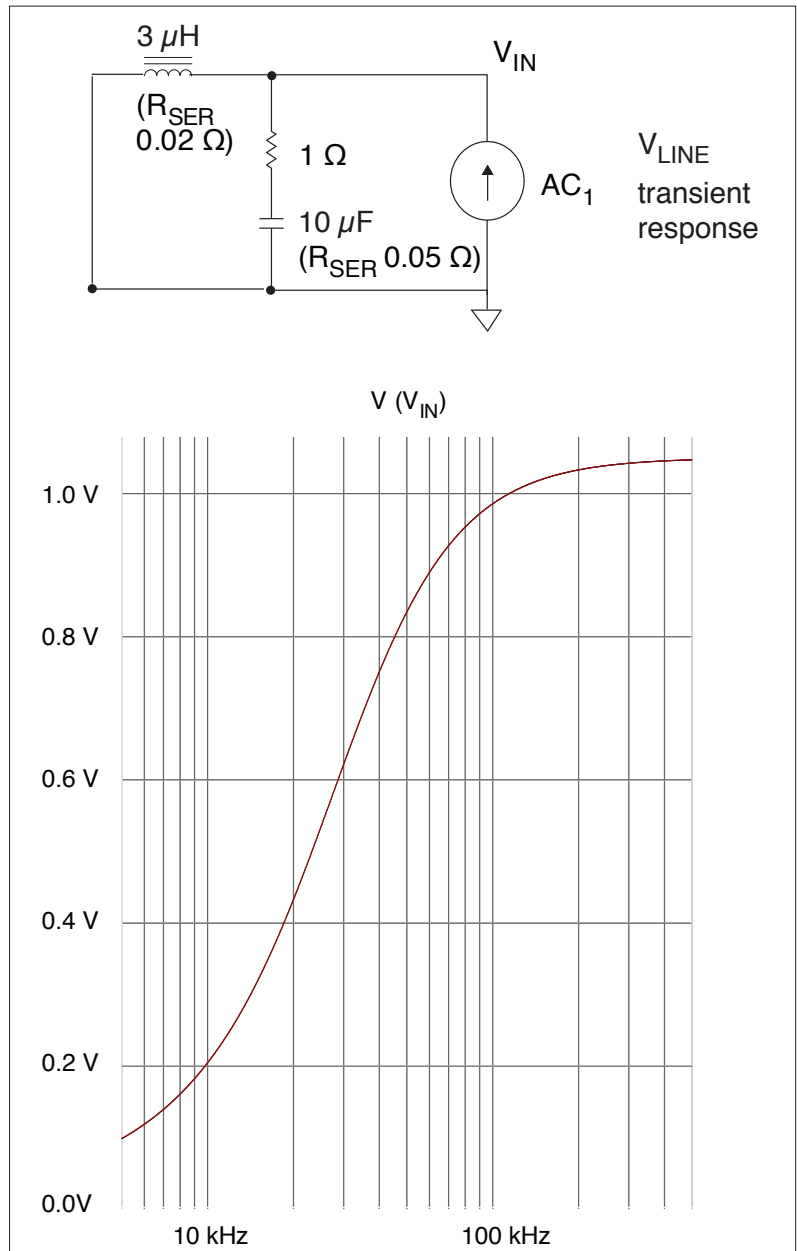

FIGURE 8: TRANSIENT RESPONSE

Transient Suppression: Switching Power Supplies

INTERPOINT® APPLICATION NOTE

$L = N^2 * A_L$ where

L = inductance value

N = number of turns

$A_L = 14 \text{ nH}$ (for the 58292)

The formula for magnetizing force is

$H = A * T / l_e$ where

H = magnetizing force in ampere turns per cm

A = the maximum inductor current (10 amps in our example)

T = number of turns (15 turns in our example)

l_e = the core magnetic path length (2.18 cm for the 58292)

Using 15 turns on the 58292 core the initial inductance is 3.15 μH .

The A_L values assume 1,000 turns. With 15 turns the actual inductance can be slightly higher. We will assume 3.15 μH for our example. With 5 amps of current (the average current over time) the magnetizing force is 34 ($A * T / l_e$) and the inductance drops to 98 % of its initial permeability, or to 3.1 μH . With 10 amps of current, the magnetizing force is 69 ($A * T / l_e$) and the inductance has dropped to about 94% of its permeability, or 3 μH . Any current being drawn by a converter also needs to be considered. The “% Initial Permeability versus H (AT/cm)” curves are shown in Figure 9. We are only interested in the curve that represents the 26 μ material.

High Flux Toroids

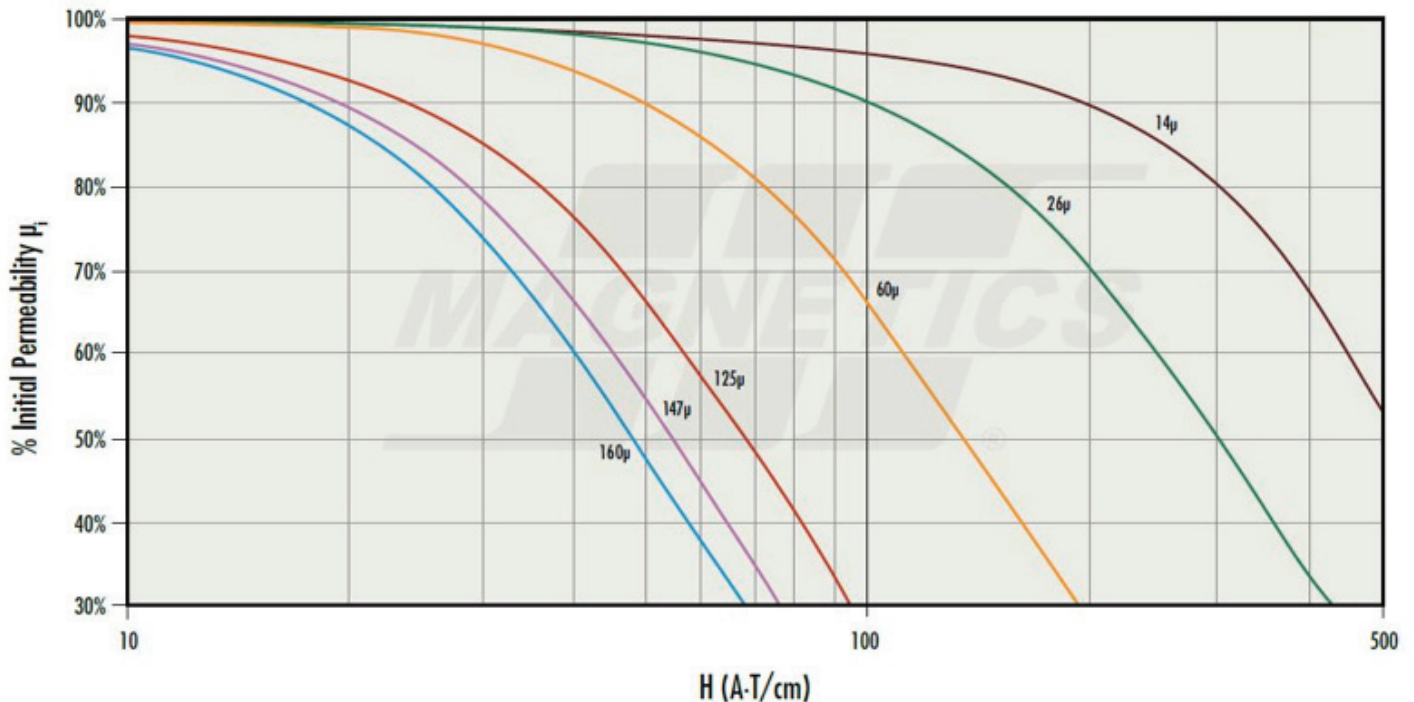

FIGURE 9: PERMEABILITY VS H (IMAGE COURTESY OF MAGNETICS. COM)

Transient Suppression: Switching Power Supplies

INTERPOINT® APPLICATION NOTE

The model with a 200 volt, 0.15 μs stimulus using a 3 μH inductor, 10 μF capacitor is shown in Figure 10 along with the simulation results. The maximum voltage at the output of the LC filter is almost 37.5 volt and the inductor current is a little less than 9 amps. The model does not account for decreased inductance due to magnetizing force so this would be an approximation. Since there is little change of inductance the simulation results should be very close. With 15 turns on the 58292 core the window area still has space so a slightly smaller core with more windings may also be a possibility.

The 10 μs , 200 volt transient will require a much larger inductor if the same method of suppression is used. If we want to limit the transient current to 20 amps, for example, then the inductor value will be 100 μH . Here, we will use a TVS to clamp the line voltage and select a 100 μF capacitor. For this application we will assume the converter draws 2 amps of input current at 28 volts and the normal operating input voltage is from 24 to 32 volts. The core chosen is the 58932, high flux core from Magnetics with a permeability of 26. This has an outside diameter of 1.06 inches with a height of 0.44 inches. We will need to determine the number of turns needed to achieve 100 μH for this core.

$$L = N^2 * A_L \text{ where}$$

$$L = \text{inductor value (100 } \mu\text{H)}$$

$$N = \text{number of turns}$$

$$A_L = 32 \text{ nH (for 58932 core)}$$

Solving for N we get 56 turns.

The formula for magnetizing force is

$$H = A * T / l_e \text{ where}$$

$$H = \text{magnetizing force in ampere turns per cm}$$

$$A = \text{the inductor current (20 amps in our example)}$$

$$T = \text{number of turns (56 turns in our example)}$$

$$l_e = \text{the core magnetic path length}$$

$$(6.35 \text{ cm for the 58932)}$$

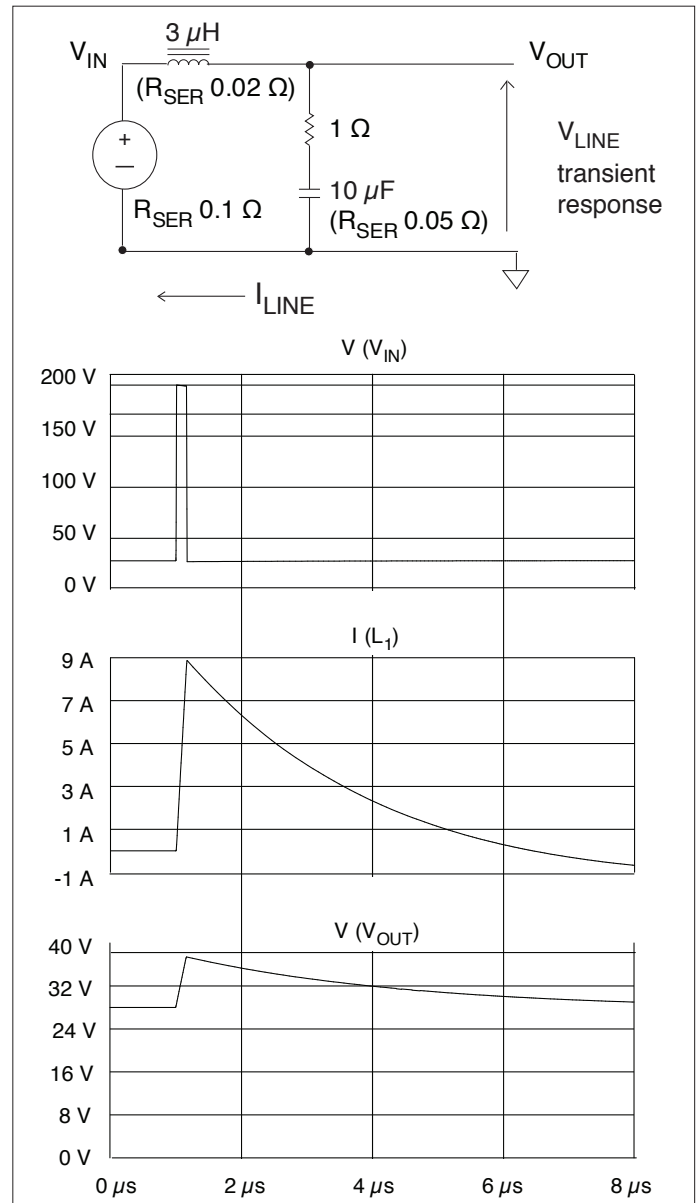

FIGURE 10: TRANSIENT RESPONSE

Transient Suppression: Switching Power Supplies

INTERPOINT® APPLICATION NOTE

Assuming 20 amps of current and solving for H we get 176 A*T/cm. Looking at the graph of Permeability versus H in Figure 9 we see that at 176 A*T/cm the inductance drops to approximately 77% of its initial value or 77 μ H which is too low. We will increase the number of turns to 62 which gives an initial inductance of 123 μ H and a new H of 195 A*T/cm. Now looking at the graph of permeability versus H we see the inductance drops to around 71% of its original value or to 87 μ H. Since it will take time for the current to build up in the inductor the average current should be less than 20 amps, using an inductance value of 100 μ H should be fine. We will use 62 turns of 22 AWG wire which will create approximately 0.12 ohms of resistance that we will add to our model. This particular core size is also available in the "XFlux" material (core 78932). The XFlux material from Magnetics can also handle the higher bias currents at a much lower cost but at this writing the cores sizes are limited especially in the smaller geometries.

Using Spice and optimizing the Q and impedance of the filter, a 1.2 ohms resistor in series with the 100 μ F capacitor is a good choice. The Q is less than 1.3 using inductance values of 87 μ H to 123 μ H. Figure 11 shows the model and the Q of the filter. Figure 12 shows the transient model where B₁ is a behavior model representing a converter's negative impedance that draws 2 amps at 28 volts, 56 watts. The TVS chosen is the surface mount part SMCJ33A which has a reverse stand-off voltage of 33 volts. If the normal operating range for the input voltage is close to this value another device with a higher breakdown voltage should be chosen. The simulation results in Figure 12 show that the voltage is clamped to less than 43 volt and the current in the inductor is less than 18 amps. The model does not take saturation of the inductor into account and removing the load does not significantly change the results.

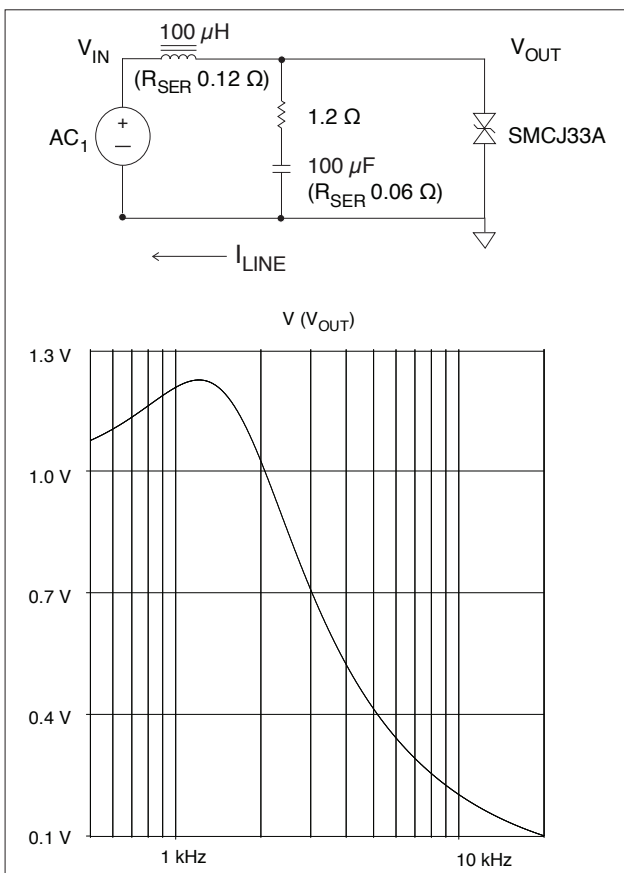

FIGURE 11: MODEL AND Q OF THE FILTER

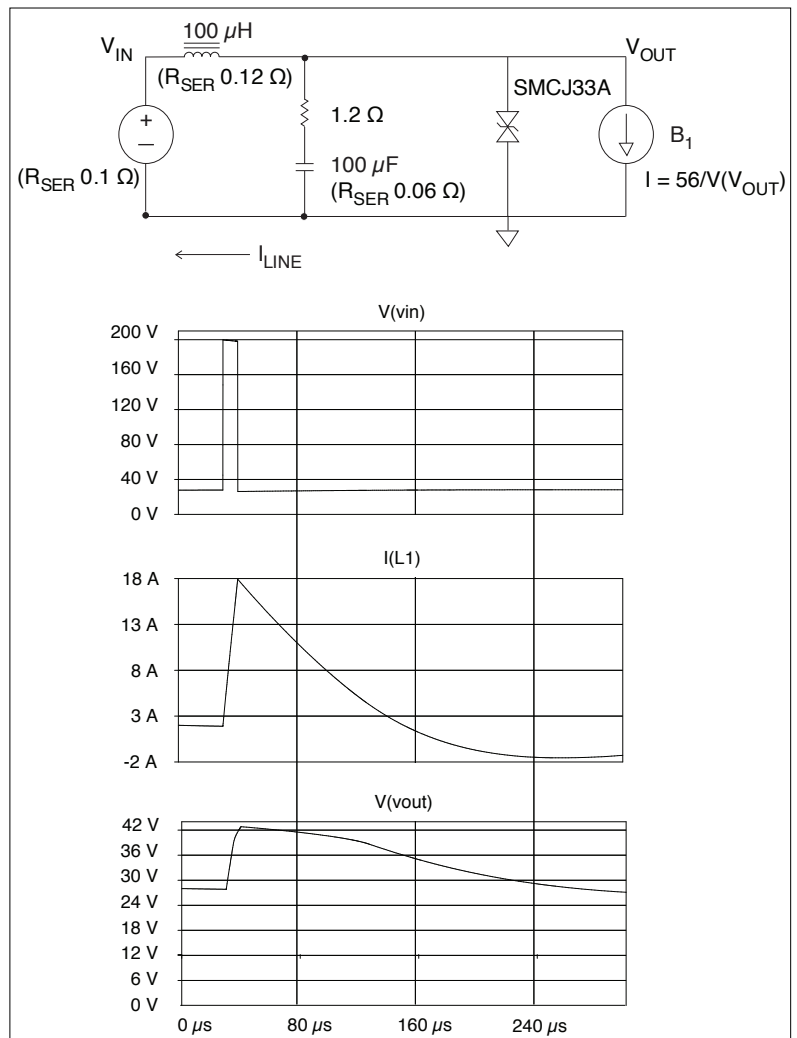

FIGURE 12: TRANSIENT MODEL

Transient Suppression: Switching Power Supplies

INTERPOINT® APPLICATION NOTE

Some applications have limitations on the maximum allowable input current, or a bus may have a fuse that may be at risk with high current. These need to be considered when determining the approach.

The next step would be to ensure that the impedance created by the added circuitry is lower than the converter's input impedance. Figure 13 shows the impedance model and simulation results. Since the current through the inductor is 2 amps the magnetizing force is negligible. We have used 123 μH for our simulation. The higher inductance value should also create the highest resonant impedance. The simulation results show the impedance is less than 1.5 ohms which should be fine for this application which is less than 56 watts. If other

circuits are a part of the system design they would also need to be included in the models. Even without the TVS used for this application the voltage would be limited to less than 50 volts which is acceptable for most applications. The capacitor does not need to be 100 μF in order to limit the transient but lower values, such as 47 μF , create a higher Q and a higher source impedance. All of these need to be considered on their own merit and for the particular application. A stripper can also be considered as an alternate solution. This is covered in later paragraphs.

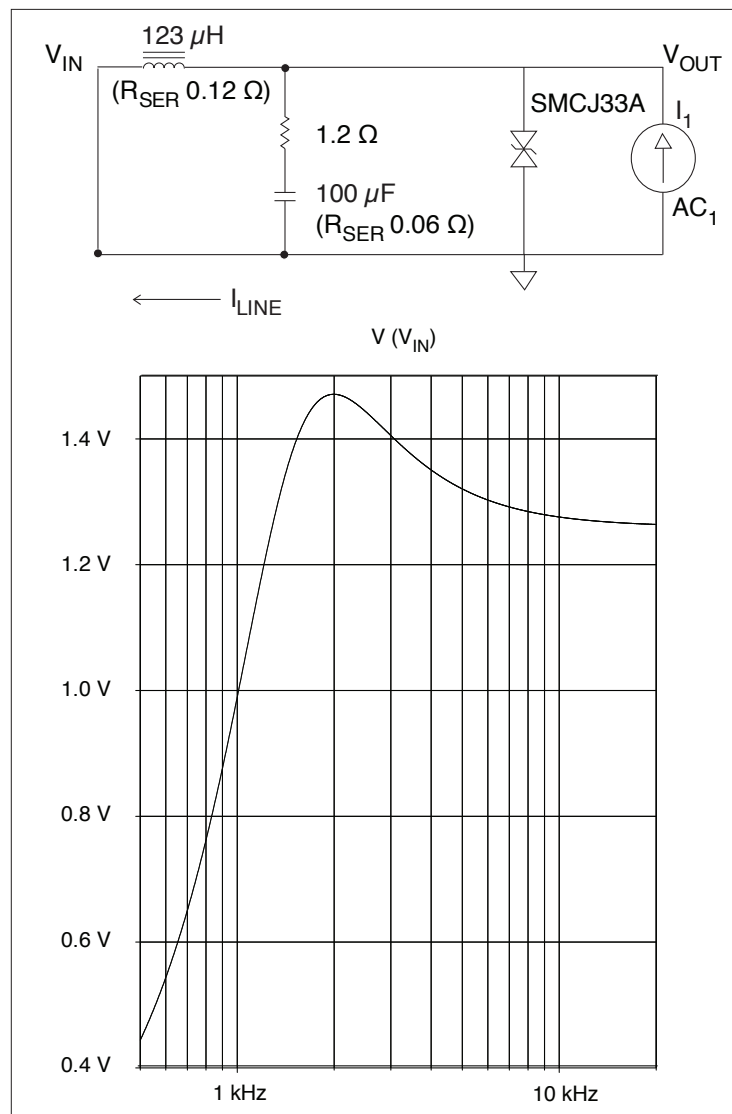

FIGURE 13: IMPEDANCE MODEL AND SIMULATION

Transient Suppression: Switching Power Supplies

INTERPOINT® APPLICATION NOTE

LIMITED ENERGY TRANSIENTS

MIL-STD-1275A has a transient with an energy limit of 0.015 joules, or 0.015 watt seconds. The transient is shown in Figure 14, and occurs over a time period of 1 millisecond. The total power won't exceed $(.015) / (.001) = 15$ watts, which can be clamped with a small TVS at approximately 40 volts. A shunt capacitor can also be used for suppression, and the minimum value capacitor can be calculated from energy storage equations as shown in the following example assuming a nominal input voltage of 28 volts and a maximum of 40 volts. This does not take into consideration any current that may be drawn by the converter.

$$\begin{aligned} C_{\text{MIN}} &= (2 \times P \times \Delta t) / (V_1^2 - V_2^2) \\ &= (0.03) / (40^2 - 28^2) \\ &= 37 \mu\text{F} \end{aligned}$$

DROPOUT TRANSIENTS

During dropout transients, the power line can be held up with a battery or pre-charged capacitor connected to the power line through a reverse rectifier. Interpoint holdup modules charge up an external capacitor to about 40 volts, and then connect it to the internal power line through a FET switch when dropout occurs. These devices are HUM-40 and HUM-70. The "HUMMER" (HUM-40 and HUM-70) datasheet has a wealth of technical information on the subject and when the parts are used in an application, a significant reduction in the volume of capacitance needed will result. Where a capacitor is to be used for holdup, the minimum value of capacitance required can be calculated from:

$$C = 2P\Delta T / (V_{\text{CH}}^2 - V_{\text{LL}}^2), \text{ where,}$$

P = input power in watts,

ΔT = dropout time in seconds,

V_{CH} = holdup capacitor voltage at dropout,

V_{LL} = low line voltage where power supply loses regulation, usually less than 16 volts.

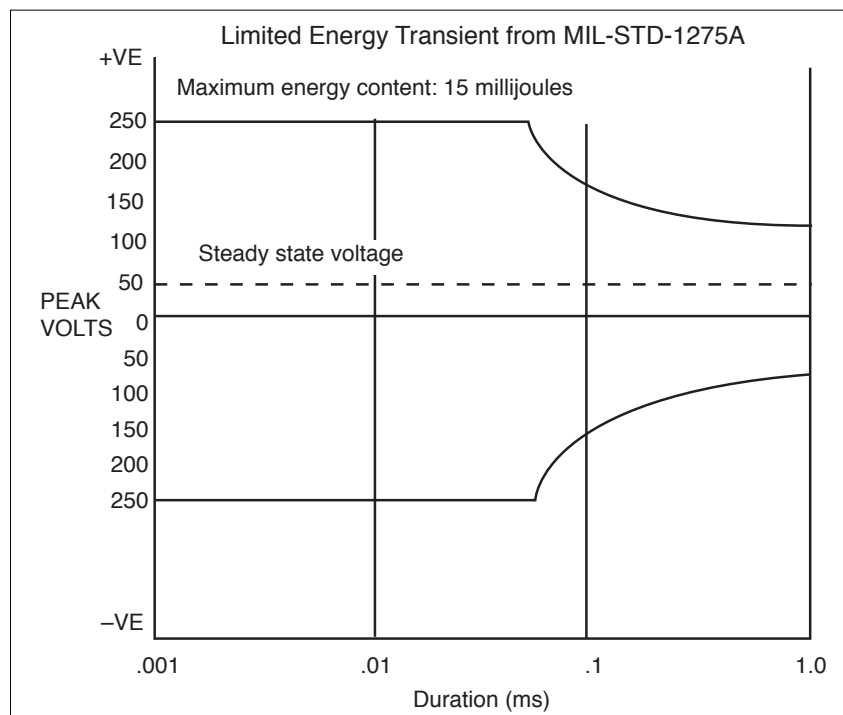

FIGURE 14: MIL-STD-1275A LIMITED ENERGY TRANSIENT

Transient Suppression: Switching Power Supplies

INTERPOINT® APPLICATION NOTE

LONG TERM TRANSIENTS

Long term transients, as defined here, are those which have a duration of 50 to 100 milliseconds, then decay to the nominal line voltage within 50 milliseconds to one second or more. Examples are the 80 volt transient of MIL-STD-704A, and the 100 volt transient of MIL-STD-1275A. The latter has a defined source impedance of 0.5 ohms. The 704A transient does not have a defined source Z, and the value could range from a few milliohms to a half ohm for individual systems. Refer to Figure 15 for examples.

Transients like these have too large a volt second product to be suppressed by conventional energy storage means as in the previous examples. The L and C components would be much too large. This would also be generally true for transients having a low source Z and durations in excess of a few tens of μ s. Transorbs can also be used for these as well as the longer duration transients, but they may be large, and safe energy as well as peak current ratings need to be observed. The current limiting devices in series with the transorb would also burn significant energy.

A buck switching regulator is the most efficient means of rejecting the long term transients, but it generates its own noise and requires a finite time to get up and running, typically about a millisecond. For fast transients, this would not work well. The stripper, which functions as a linear regulator during the transient, is the best overall solution. The Interpoint FM-704A combines a stripper and an EMI filter while limiting the conducted emissions of Interpoint brand converters below MIL-STD-461 C, CE03 levels. During a line transient the FM-704A will clamp its output voltage to less than 40 volts while providing up to 40 watts to power a converter. The FM-704A uses a pair of N channel power FETs in the positive rail and a charge pump to obtain gate enhancement above the +28 volt line. Refer to the data sheet for the functional schematic and other useful information.

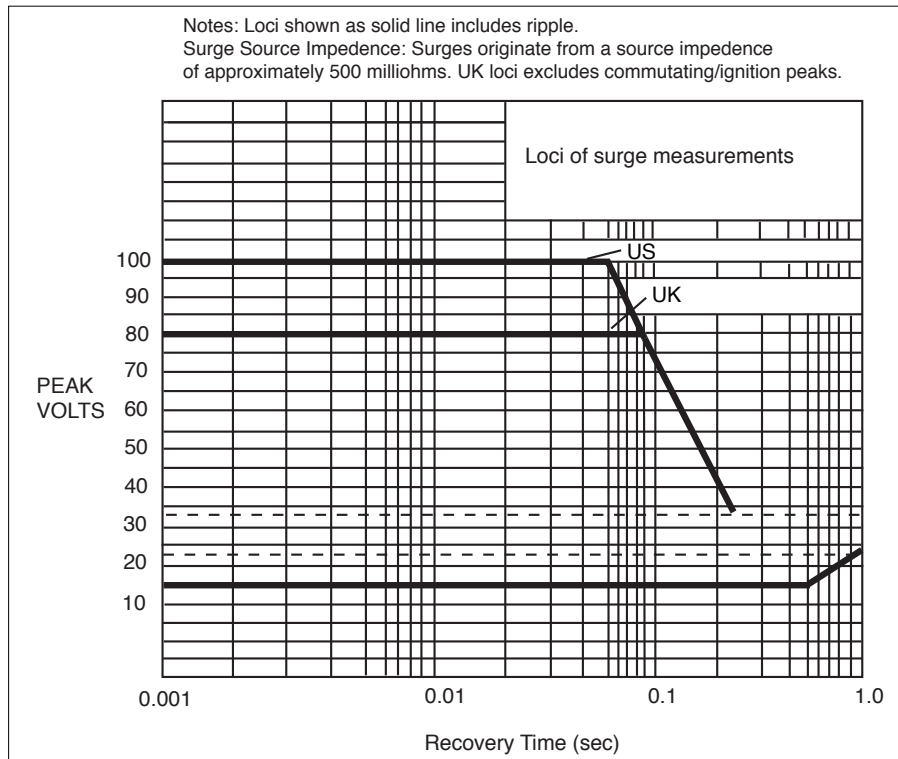

FIGURE 15: MIL-STD-1275A LOW IMPEDANCE TRANSIENTS

Transient Suppression: Switching Power Supplies

INTERPOINT® APPLICATION NOTE

An example of a stripper is shown on Figure 16. This uses an N channel FET in the return line to clamp the voltage. Under normal operation the FET is in full enhancement with its “R_{ds on}” in series with the power line. When activated by a transient, the FET operates in its linear region becoming a linear regulator. In the linear mode the stripper regulates its output in the 40 to 50 volt area, with the balance of the transient appearing across the series FET. The FET current during the transient is the load current at the regulated output voltage. In the case of a switching power converter load, where the regulated output is 45 volts, the current will be about 60% of its 28 volt value. The safe operating area as well as the total energy absorbed during the transient need to be considered in the design of a stripper. A FET in the return line can limit the use of a converter's inhibit or sync function if these are referenced to the source side of the FET.

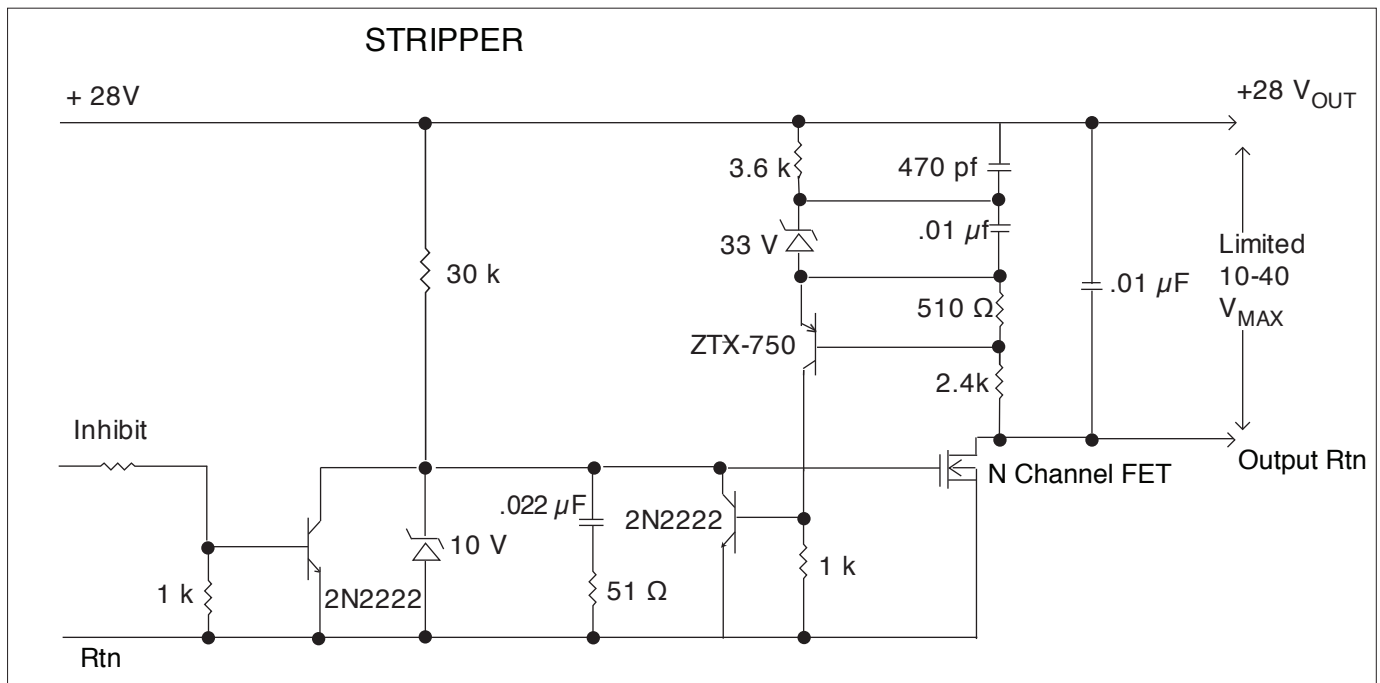

FIGURE 16: TRANSIENT STRIPPER

Transient Suppression: Switching Power Supplies

INTERPOINT® APPLICATION NOTE

INDUCED CURRENT TRANSIENTS

Induced current transients caused by EMP or high level signals in adjacent wiring can be common mode, differential mode, or a combination of the two in nature. The example of Figure 17 is from MIL-STD-461C, method CS11, and is common mode in nature. This transient can be suppressed with good quality ceramic capacitors from both the +28 volt and the return line to the power converter cases assuming the converter's case has a low impedance connection to the test ground plane. In case of unbalance, a capacitor can be placed across the lines also. The minimum capacitor value is easily calculated once a maximum acceptable voltage deviation is defined. If we assume a maximum voltage deviation of 1.0 volt is allowable, the minimum capacitance is 2.7 μ F. Refer to Figure 17 for the details. The capacitors can also be paralleled with transorbs which may be effective in suppressing lightning induced transients.

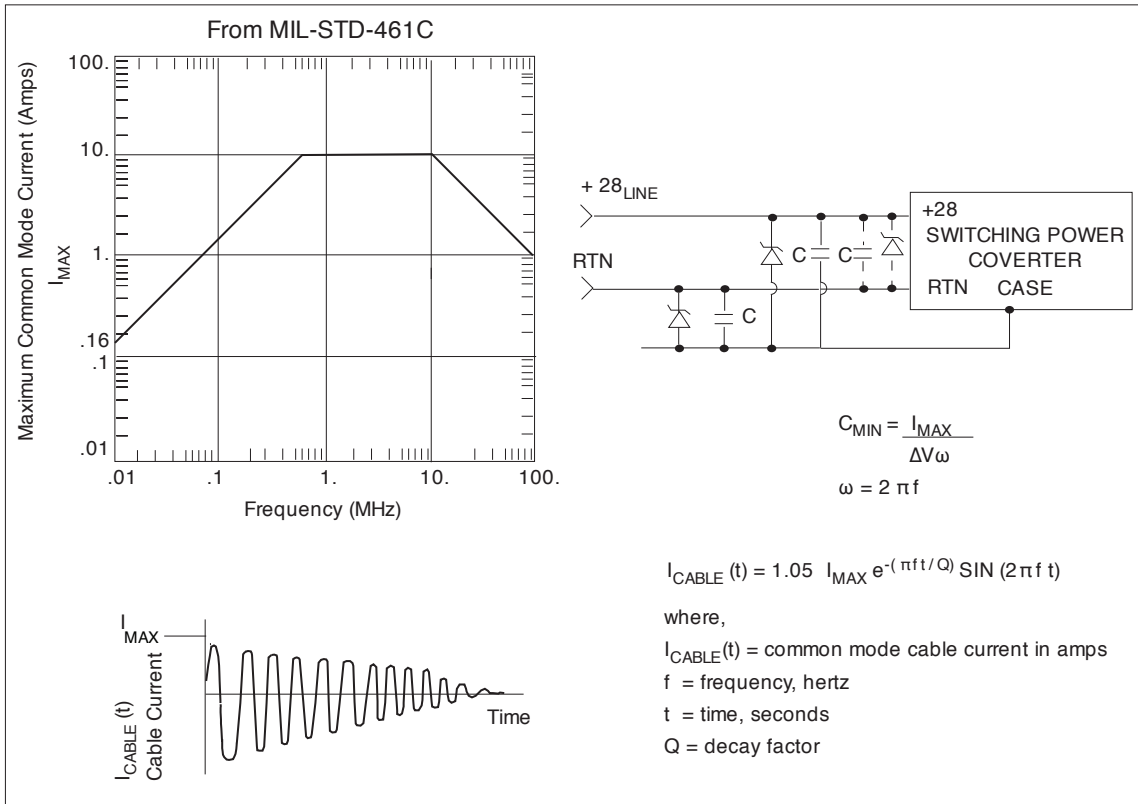

FIGURE 17: INDUCED CURRENT TRANSIENT – MIL-STD-461C, METHOD CS11